



"focus differently"

USER MANUAL

Version V.1.4

VS86P/VS86I Series
PAM MODEM

Models :
VS86P/VS86I

www.xentino.com

Table of Contents

Version Control	7
Safety Regulations	8
EU Directive 2002/96/EC AND EN50419	8
1 Selection Guide	9
2 Precaution	10
3 General Information	11
4 Service instructions	12
5 Quick Installation GUIDE	13
5.1 Resetting the SFP modem to its factory settings (optional)	13
5.2 Enter Xentino VS86P/VS86I SFP Copper Wire Modem	14
Access with Telnet	14
Access with WEB	15
5.3 Configure Xentino VS86P/VS86I SFP Modem	15
Description of Operating Modes.....	15
Recommendations for Mode Selection	16
Configuring Fixed Rate Mode via Telnet	18
Configuring Fixed Rate Mode via WEB.....	20
Configuring Auto Rate Mode via Telnet.....	24
Configuring Auto Rate Mode via WEB	26
5.4 Checking of Link Quality and Baserate adjustment	30
5.5 Approximate transmission range.....	31
5.6 Problem with Xentino VS86P/VS86I SFP Copper Wire Modem	31
6 Technical Description	31
6.1 Description of Xentino VS86P/VS86I SFP Copper Wire Modem	31
6.2 Interface Description	34
Copper Wire modem Interface	34
Master/Slave	34
Fixed and Auto Rate Modes.....	34
Link Quality Monitoring.....	35
Fast Link Recovery	35
Automatic Active Remote Device Detection.....	36
Ethernet Interface (SFP Host Interface).....	36
Alarm Description	37
6.3 Management of Xentino VS86P/VS86I SFP Copper Wire Modem	38
Default IP Address	38
Telnet.....	38
WEB	39
I2C.....	40
7 Diagnostic and Control/Status Fields Memory Map	41

7.1	Base/Extended ID Fields, Address A0h.....	42
7.2	Diagnostic and Control/Status Fields, Address A2h.....	43
8	Programming guide.....	43
8.1	Command Structure.....	43
8.2	Xentino VS86P/VS86I Software.....	44
8.3	Configuration and Application Storage.....	45
8.4	Command Syntax.....	45
8.5	Commands.....	46
	Main Menu.....	46
	System Invitation.....	46
	General Commands.....	46
	<H> Command.....	46
	<M> Command.....	47
	Fault and Maintenance Management Menu.....	47
	<H> Command.....	47
	<SFPVIEW> Command.....	47
	<RESET> Command.....	49
	CX_FMM>RESET.....	49
	<SERNUM> Command.....	49
	CX_FMM>SERNUM.....	49
	BPR242200002.....	49
	CX_FMM>.....	49
	<SOFTUPDATE> Command.....	49
	<SOFTINFO> Command.....	50
	<STATUS> Command.....	50
	<TFTP SOFTUPDATE [FILEPATH]> Command.....	51
	Configuration Management Menu.....	52
	<H> Command.....	52
	<MASTER ON/OFF> Command.....	53
	<BASERATE M/AUTO> Command.....	53
	<ETHSD 100/1000/AUTO> Command.....	54
	<FC ON/OFF> Command.....	54
	<GATEWAY X.X.X.X> Command.....	54
	<NETCONFIG> Command.....	54
	<NETMASK X.X.X.X> Command.....	55
	<SETIP X.X.X.X> Command.....	55
	<TFTPIP IP/OFF> Command.....	56
	<TFTP RETRIES [1..10]> Command.....	56
	<TFTP TIMEOUT [1..60]> Command.....	56
	<TFTP FILEPATH [str]> Command.....	56
	<TELNET ON/OFF> Command.....	56
	<HTTP ON/OFF> Command.....	56
	<COMPAT <param>/OFF> Command.....	56
	<PASSWORD > Command.....	56
	<SOFTSELECT 1/2> Command.....	57

<FACTORY DEFAULT> Command	57
<APPLY> Command.....	57
9 Software download.....	57
9.1 Using SOFTUPDATE cmd with 1K-XMODEM (fastest method)	57
9.2 Using TFTP SOFTUPDATE cmd.....	58
9.3 SW Update using WEB	60
Configuring through WEB	60
Software update through WEB	60
10 Connector Description	61
10.1 SFP Modem Connector.....	61
SFP Module VS86P	61
SFP Module VS86I	61
10.2 SFP Host Connector	62
11 Technical Specification	62
11.1 Interfaces	62
SFP Copper Wire Modem Interface	62
SFP Host Interface	63
11.2 Power Supply (SFP Host Connector Power, MSA Compliant)	63
11.3 SFP Latency	63
11.4 SFP Jitter	63
11.5 Environment.....	63
Climatic Conditions.....	63
EMC and Safety Standards	63
11.6 ROHS / WEEE	64
11.7 MTBF.....	64
11.8 Mechanical Specification.....	64

XENTINO VS86P/VS86I SERIES COPPER WIRE SFP PAM MODEM
INSTALLATION GUIDE, TECHNICAL DESCRIPTION AND OPERATIONS MANUAL

© Copyright 2026 by Xentino Technologies Corp. The content of this publication may not be reproduced in any part or as a whole, transcribed, stored in a retrieval system, translated into any language, or transmitted in any form or by any means, electronic, mechanical, magnetic, optical, chemical, photocopying, manual, or otherwise, without the prior written permission of Xentino Technologies Corp. Published by Xentino Technologies Corp. All rights reserved.

VERSION CONTROL

Manual Version	Date	Software Version	Major changes to previous version
1.0	13.06.2024	1.0	Initial Version
1.1	28.06.2024	1.2	<ul style="list-style-type: none"> • Link behaviour in some configurations changed • Description of Fixed and Auto modes extended • Description of Fast Link recovery added Chapter 3 updated Chapter 5.3 changed Chapter 5.4 changed Chapter 6 changed Chapter 8.5.4.2 updated Chapter 8.5.4.3 updated
1.2	02.07.2024	1.3	Telnet and WEB access can be disabled
1.3	29.08.2025	1.7	<ul style="list-style-type: none"> • All menu displays updated according to SW version 1.7 • New COMPAT cmd added • Chapter 6.3.4 added (I2C Management) • Chapter and 7.1 and 7.2 added / updated • Chapter 8.5.4.18 updated Factory Default ETH speed to 1000F • Chapter 11.1.1 Transmit Bandwidth updated
1.4	19.11.2025	1.9	<ul style="list-style-type: none"> • Updated Miscellaneous WEB screens • Chapter 8.1 updated • Chapter 8.5.4.17 added new PASSWORD cmd • Chapter 8.5.4.19 actualized Factory Defaults

SAFETY REGULATIONS

IF THE UNIT IS NOT USED IN ACCORDANCE WITH REGULATIONS DESCRIBED AND DEFINED IN THE CHAPTERS "TECHNICAL DESCRIPTION" AND "TECHNICAL SPECIFICATIONS," Xentino Technologies Corp REFUSES TO TAKE ANY RESPONSIBILITY. FURTHERMORE, NO WARRANTY IS GRANTED IN SUCH CASE!

IT'S ONLY ALLOWED TO PLUG THE SFP MODULE INTO EQUIPMENT CONNECTED PERMANENTLY TO RELIABLE PROTECTIVE EARTH CONDUCTOR.

INCORRECT USE OF THIS DEVICE, USE IN ANY OTHER ENVIRONMENT AND/OR HOUSING THAN PROVIDED BY XENTINO MIGHT LEAD TO HARMFUL CONDITIONS. FAILURE TO FOLLOW THESE PRECAUTIONS MAY RESULT IN DEATH, SEVERE INJURY OR PROPERTY DAMAGE.

Please read this manual carefully before operating the system.

Installation of this equipment has to be done by **qualified** personnel only.

EU DIRECTIVE 2002/96/EC AND EN50419



Our equipment is marked with the recycling symbol. It means that at the end of the life of the equipment you must dispose it separately at an appropriate collection point and not place it in the normal domestic unsorted waste stream. (European Union only)

1 Selection Guide

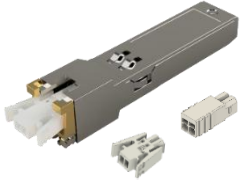
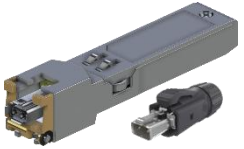
Part Number	Description	
VS86P	Industrial 1.5..18Mbps SFP Ethernet Copper Wire Modem (PAM), up to 6200 Meter, 100BASE-FX/1000BASE-X SFP, -40°C to 85°C, AWG 18-26 Combicon XC with Snap-in Locking connector.	
VS86I	Industrial 1.5..18Mbps SFP Ethernet Copper Wire Modem (PAM), up to 6200 Meter, 100BASE-FX/1000BASE-X SFP, -40°C to 85°C, AWG 18-28 IEC 63171-6 Compliant with Metal Latch connector.	

Matching Cables for VS86I

Part Number	Description	
VS86-I0001	SPE IP20 Plug-Plug Cable 1m	
VS86-I0002	SPE IP20 Plug-Plug Cable 2m	
VS86-I0003	SPE IP20 Plug-Plug Cable 3m	
VS86-I0004	SPE IP20 Plug-Plug Cable 4m	
VS86-I0005	SPE IP20 Plug-Plug Cable 5m	
VS86-I0010	SPE IP20 Plug-Plug Cable 10m	
VS86-I0020	SPE IP20 Plug-Plug Cable 20m	
VS86-I0050	SPE IP20 Plug-Plug Cable 50m	
VS86-I0100	SPE IP20 Plug-Plug Cable 100m	

2 Precaution

The present document describes Xentino **VS86P/VS86I** Copper Wire SFP PAM modems. The document contains the technical description of the modems, installation, configuration, and operation instructions.



WARNING

THIS EQUIPMENT IS NOT SUITABLE FOR USE IN LOCATIONS WHERE CHILDREN ARE LIKELY TO BE PRESENT.



WARNING

BEFORE STARTING OPERATING THE EQUIPMENT, READ CAREFULLY THE CURRENT DOCUMENT. XENTINO TECHNOLOGIES CORP REFUSES NEITHER TAKING ANY RESPONSIBILITY NOR GRANTING ANY WARRANTY TO ANY SFP MODEM MALFUNCTIONING OR ANY DAMAGES DUE TO FAILURE TO COMPLY WITH THE REQUIREMENTS STATED IN THE MANUALS, ESPECIALLY IN THE SECTION RELATED TO "SERVICE INSTRUCTIONS."



WARNING

IMPROPER USE OF OUR EQUIPMENT, USE IN ANY OTHER ENVIRONMENT OR IMPROPER INSTALLATION AND MAINTENANCE MIGHT LEAD TO HARMFUL CONDITIONS. FAILURE TO FOLLOW THESE PRECAUTIONS MAY RESULT IN DEATH, SEVERE INJURY OR PROPERTY DAMAGE.

XENTINO TECHNOLOGIES CORP REFUSES NEITHER TAKING ANY RESPONSIBILITY NOR GRANTING ANY WARRANTY IN SUCH CASE.



WARNING

ELECTRONIC MODULES CAN BE DAMAGED OR DECREASED IN RELIABILITY BY STATIC ELECTRICAL DISCHARGE. BEFORE HANDLING MODULES, WEAR AN ANTISTATIC DISCHARGE WRIST STRAP TO PREVENT DAMAGE TO ELECTRONIC COMPONENTS. PLACE MODULES IN ANTISTATIC PACKING MATERIAL WHEN TRANSPORTING OR STORING. WHEN WORKING ON MODULES, ALWAYS PLACE THEM ON AN APPROVED ANTISTATIC MAT THAT IS ELECTRICALLY GROUNDED. TO PREVENT ELECTRICAL SHOCK, DO NOT INSTALL EQUIPMENT IN A WET LOCATION OR DURING A LIGHTNING STORM.



WARNING

THE PROTECTIVE GROUND CONNECTION MUST BE APPLIED TO THE HOST UNIT. MAKE SURE THAT THE HOST UNIT AND ALL EQUIPMENT CONNECTED TO IT USE THE SAME PROTECTIVE GROUND FOR THE PURPOSE OF REDUCING NOISE INTERFERENCE AND SAFETY HAZARDS.

3 General Information

The **Xentino VS86P/VS86I** is a single pair, low power SFP (Small Form-factor Pluggable) Ethernet copper wire PAM modem. The modem is optimized for a duplex connection speed in the range of 1.5...18Mbps over a pair of copper wires up to 6200 meters.

The **Xentino VS86P/VS86I** SFP modem can be plugged into any Ethernet device with SFP ports that support 100BASE-FX and/or 1000BASE-X.

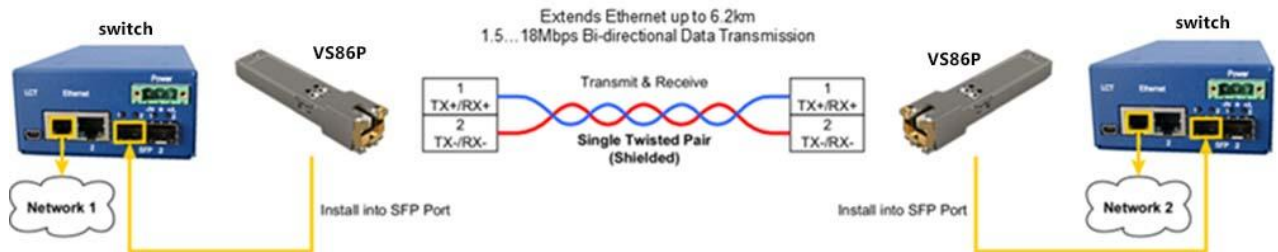

Figure 3.1 Application Example.

The **Xentino VS86P/VS86I** modem uses the transmission friendly Pulse Amplitude Modulation (PAM) technology. It means a much smaller frequency bandwidth than comparable modules with VDSL/ADSL technology. This technology influences the other systems less and the transmission on copper cables is more save and for harsh environments.

The modem supports fixed and automatic transmission rate selection. The training or recovery time for the copper line connection (link synchronisation) in Fixed Rate Mode is very fast and happens within 2..10 seconds. In Auto Rate Mode, SFP modems automatically adjust the transmission rate to the optimum performance that line conditions can support.

The Link Quality Monitoring provides performance information of a specific link and can be used during installation and maintenance procedures.

Devices also support Fast Link Recovery that helps fast connection re-establishing in case of short, less than 2 seconds, transmission losses caused by such phenomena as over voltage spikes, short interruptions or short cuts caused by over voltage protection.

The Automatic Active Device Detection feature allows SFP modem to detect the presence of an active device on the remote side of the line or to recognize the line failure.

The SFP copper line interface has 1500V RMS or 2250V DC isolation and its protection meets ITU-T Rec. K.20/K.21.

The configuration is possible by Web or Telnet access. For security purposes, Telnet and/or WEB access can be disabled after configuring.

4 Service instructions

- Before unpacking, check if the packing box is intact and if the SFP model is equal to that specified in the purchase order/contract.
- Before installation of the SFP, read carefully the present technical description and service instructions. Take care about all Warnings inside this manual! Remember that the guarantee and the free-of-charge repair will not be granted under the following conditions:
 - a) If the SFP or any of its parts fails due to improper installation, testing or operation.
 - b) damages resulting from:
 - 1) Misuse and improper installation, including but not limited to:
 - to use the product for its normal purpose or in accordance with the all the instructions for the proper use and maintenance,
 - installation and use of the product in a conflicting way with the actual technical or safety standards in the country where it is installed.
 - 2) Maintenance or repair performed by unauthorized service centers and dealers.
 - 3) Operation of a malfunctioning SFP.
 - 4) Accidents, lightning strokes, flooding, water, fire, improper ventilation, voltage drops, ingress of moisture and insects inside the equipment as well as other reasons, for example, electromagnetic and other interferences which are beyond the supplier control and do not correspond to specified technical conditions.
 - 5) Transportation except when the shipping is performed by an authorized dealer or a service center.
 - 7) Defects of the system (host equipment) into which this product is included.
- Before installation of the SFP make sure that the host equipment properly grounded.
- Environment requirements: Temperature: from -40 to +85 °C; Relative air humidity: from 5% to 95% at +25 °C. Exceptions are units that are specified from the manufacturer to differ from these requirements, because there is a special application.
- It is strictly prohibited:
 - a) to alter, delete, remove or make illegible the serial number of the SFP.
 - b) to adapt, adjust and change the equipment in order to improve it or extend its applications without the prior written consent of the manufacturer.
 - c) to alter or to adjust the equipment without the consent of the manufacturer.

5 Quick Installation GUIDE

The **Xentino VS86P/VS86I** SFP modem can be installed in any SFP port of any host equipment (for instance, switch or router), which supports 100Base-FX or 1000Base-X, i.e., Fast- or Gigabit Ethernet SFP port.

All **Xentino VS86P/VS86I** SFP modems delivered with factory default settings:

- IP: 192.168.0.1
- Subnet mask: 255.255.255.0
- Default gateway: 192.168.0.254



ATTENTION

For initial configuring your network and network settings of your PC and the host, where the SFP modem is installed, must allow accessing the default SFP modem IP address 192.168.0.1.

5.1 Resetting the SFP modem to its factory settings (optional)

To reset the SFP modem to its factory settings, a special switch located on the underside of the SFP modem's PCB can be used. To do this, follow these steps:

1. Carefully move the switch to the right position as shown below:

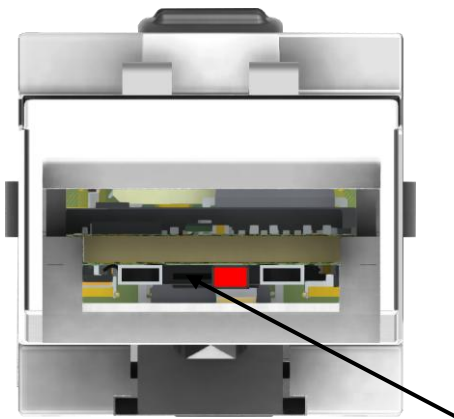

Figure 5.1 SFP modem Rear View, Switch is in the right position (Factory Default).

2. Insert SFP modem into any SFP port of powered Host and wait about 30 seconds.
3. Extract SFP modem from the Host and return the switch to the left as shown below:

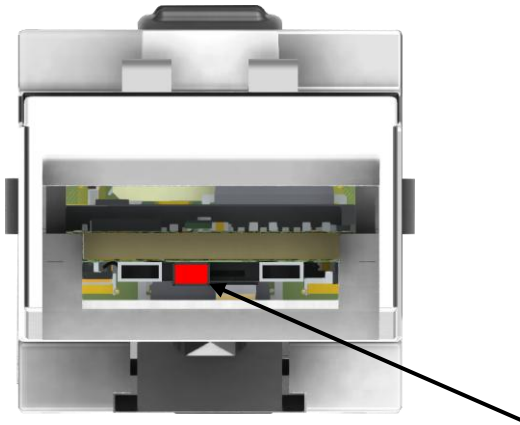

Figure 5.2 SFP modem Rear View, Switch is in the left position (Normal Operation).

Now the Factory Default settings are set and SFP modem is ready for initial configuring.

5.2 Enter Xentino VS86P/VS86I SFP Copper Wire Modem

To enter in an **Xentino VS86P/VS86I** SFP modem, use a terminal emulation program with Telnet or go with WEB.

For security purposes, you can disable Telnet and/or WEB access after configuring. If both, Telnet and WEB are disabled, then it will be necessary to reset the SFP modem to its factory settings to restore access. This can be done by using the switch, described in Chapter 5.1 above.

Access with Telnet

1. Open a program with Telnet protocol
2. Open the Telnet session with address 192.168.0.1
3. Press Enter. The Main Menu will be displayed:

```

192.168.0.1 - Tera Term VT
Datei Bearbeiten Einstellungen Steuerung Fenster Hilfe
MODEL COPSFPMSPAM
HW 01AA
SW 1.9
DATE 17-11-2025
RUNS 0d 00:06:02
ALARM URGENT (LNK)
MODEL_DESC Flexcom SFP/100BASE-FX 1000BASE-X/Copper 1.536-18.048 Mbps
IP 192.168.0.1
MAC 00:0F:D9:00:00:03

----- Main Menu -----
2. Fault and maintenance management (FMM)
3. Configuration management (CM)
5. Exit
-----
Select [1..5]
CX_MM>

```

Figure 5.3 Main Menu (Telnet)

Access with WEB

Enter the command: **http://192.168.0.1** in the WEB browser. After the connection is established the summary window of the modems WEB-GUI will be displayed:

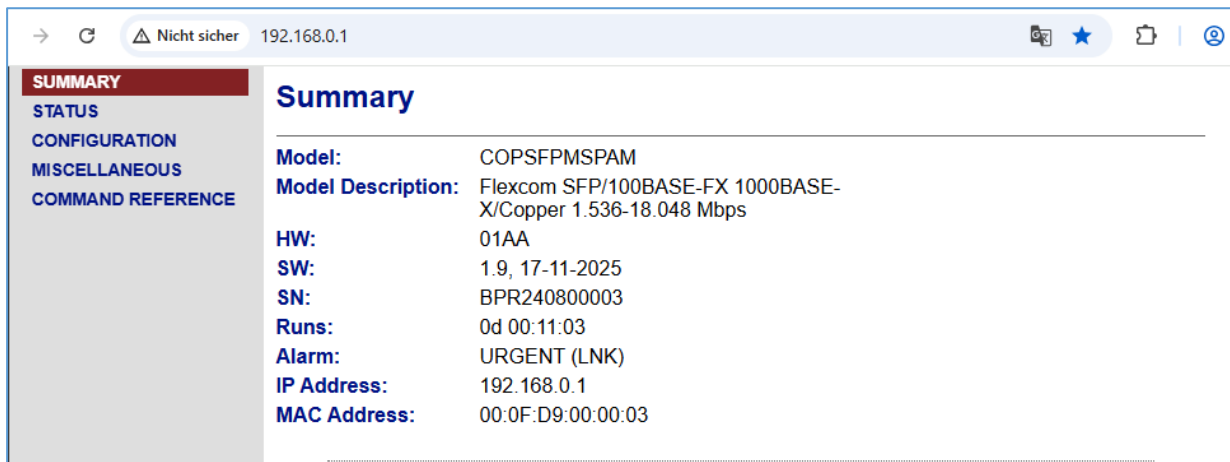

Figure 5.4 SUMMARY screen (WEB)

5.3 Configure Xentino VS86P/VS86I SFP Modem

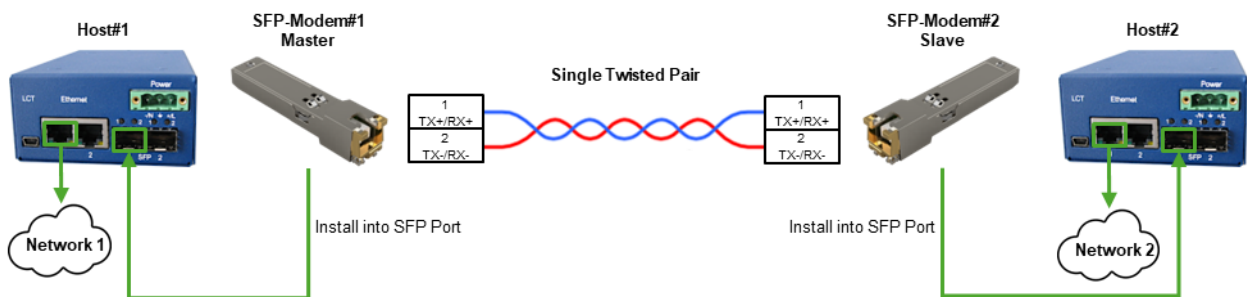

Figure 5.5 Typical Application

The Figure above represents a typical application of the SFP modems. Two standard configuration examples are given in this Chapter, one for **Fixed Rate Mode** and another for **Auto Rate Mode**.

Alternatively, it is possible to set the Master modem (SFP-Modem#1) to **Fixed Rate Mode** and the Slave modem (SFP-Modem#2) to **Auto Rate Mode**.

Please find below the description of **Fixed Rate** and **Auto Rate** modes and recommendations for mode selection.

Description of Operating Modes

The modem supports two operating modes: **Fixed Rate Mode** and **Auto Rate Mode**.

1. Fixed Rate Mode (fast link establishing)

- This mode allows for fast link establishment within 2..10 seconds, depending on selected Baserate and provided that the line conditions support the specified speed.
- This mode ensures fast link establishment both after short, less than 2 seconds, interruptions and also after long line disconnections.

- In this mode, the connection speed is fixed and determined by the **Baserate** parameter, which must be set identically on both modems.
- It is very important to ensure that the line can handle the set speed; otherwise, the connection will not be established. If the line is too long or has poor quality, the **Baserate** may need to be lowered on both modems to establish a stable link. **Be aware that if the Baserate is set too high and the connection cannot be established, lowering the Baserate on one modem will not allow the connection unless it is also lowered on the remote modem. This could require the presence of personnel at the remote site to reconfigure the modem settings manually, as there might be no remote access to the modem for adjustments.**

2. *Auto Rate Mode (automatic speed adjustment)*

- This mode automatically adjusts the speed to match the optimal performance that the line conditions can support.
- Although it can take longer to establish the link (from 30 seconds to 3 minutes), it ensures that the connection is made at the highest possible speed that the line can sustain with a good signal-to-noise ratio (SNR).
- Thanks to the Fast Link Recovery feature, in Auto Rate Mode the device will quickly, within 2..10 seconds) restore the connection in case of short, less than 2 seconds, connection interruptions.

Recommendations for Mode Selection

- **Use Fixed Rate Mode** on both modems if you are confident in the quality of the line and know that it can support the specified **Baserate**. This mode is ideal for environments where rapid connection establishment is critical. Fixed Rate Mode is also optimal for short lines (for instance, less than 400 meters for standard Ethernet cables). For longer lines, you should consult the connection range estimates provided in 5.5 Approximate transmission range to determine if the line can support the desired speed. **Please note that the data in Section 5.5 is for reference only, and the actual transmission range can vary significantly based on the specific conditions of the cable.**
- **Use Auto Rate Mode** on both modems if there is any uncertainty about the line quality or if you are setting up the connection for the first time. After the connection is established, observe the **Baserate** achieved by the modems in Auto Rate Mode. You can then configure both modems with this **Baserate** in Fixed Rate Mode for future quick reconnections.
- **Alternatively, set the Master modem to Fixed Rate Mode and the Slave modem to Auto Rate Mode.** In this configuration, the master modem determines the transmission speed, and the slave modem adjusts to match it. This allows for manual speed adjustment from the Master side only, eliminating the need for personnel at the remote site (Slave). However, the connection establishment time will be similar to using Auto Rate Mode on both modems.

Once the connection with optimal Baserate is established, you can then switch the Slave modem to Fixed Rate Mode with the same Baserate as the Master modem. This will ensure quick reconnection in the future.

This approach ensures that you initially secure a reliable connection and then optimize for speed and efficiency in subsequent connections.

Please pay attention also to the table below that shows the reconnection time depending on the duration of the link interruption and selected operation modes:

Mode		Failure duration	
Master	Slave	< 2 seconds	> 2 seconds
Fixed Rate	Fixed Rate	fast recovery (2..10 sec.)	fast recovery (2..10 sec.)
Fixed or Auto Rate	Auto Rate	fast recovery (2..10 sec.)	full handshake (30.300 sec.)

Table 5.1 Connection recovery depending on the failure type and configuration

Configuring Fixed Rate Mode via Telnet

SFP-Modem#1: Enter to SFP-Modem#1 with Telnet then perform the following commands:
(The IP address, netmask and gateway shown here are for example purposes only)

Type following commands	Description
<↓>	Enter the Main Menu
3 <↓>	Go to Configuration Management (CM)
<MASTER ON> <↓>	Configure modem as Master
<BASERATE 200> <↓>	Set Fixed Rate Mode with Baserate 200
<SETIP 192.168.0.184> <↓>	Set the IP-address of the modem
<NETMASK 255.255.255.0> <↓>	Set the subnet mask
<GATEWAY 192.168.0.254> <↓>	Set the default gateway
<APPLY> <↓>	Apply and save all configurations (the SFP will restart and the Telnet connection will be closed)

Table 5.2 Initial configuring of Master modem in Fixed Rate Mode (Telnet)

Because IP address, netmask and gateway of the SFP-Modem#1 were changed, it might be necessary to change the settings of the Host#1 to access SFP-Modem#1 again.

SFP-Modem#2: Enter to SFP-Modem#2 with Telnet then perform the following commands:
(The IP address, netmask and gateway shown here are for example purposes only)

Type following commands	Description
<↓>	Enter the Main Menu
3 <↓>	Go to Configuration Management (CM)
<MASTER OFF> <↓>	Configure modem as Slave
<BASERATE 200> <↓>	Set Fixed Rate Mode with Baserate 200
<SETIP 192.168.0.183> <↓>	Set the IP-address of the modem
<NETMASK 255.255.255.0> <↓>	Set the subnet mask
<GATEWAY 192.168.0.254> <↓>	Set the default gateway
<APPLY> <↓>	Apply and save all configurations (the SFP will restart and the Telnet connection will be closed)

Table 5.3 Initial configuring of Slave modem in Fixed Rate Mode (Telnet)

Because IP address, netmask and gateway of the SFP-Modem#2 were changed, it might be necessary to change the settings of the Host#2 to access SFP-Modem#2 again.

You can check the configuration after re-establishing of Telnet connection to the SFP modems:

In Menu Configuration Management (CM) of the SFP modem, you can type NETCONFIG to check the configuration.

SFP-Modem#1:

```
192.168.0.1 - Tera Term VT
Datei Bearbeiten Einstellungen Steuerung Fenster Hilfe
-----
Configuration
-----
Copper settings
  Mode           : MASTER
  Copper Baserate : 157                10.000 Mbps
System settings
  IP address      : 192.168.0.1        MAC address 00-0F-D9-18-8E-F0
  Subnet mask     : 255.255.255.0
  Default gateway : 192.168.0.254
  Speed           : 1000F
  Flow control    : ON
Services         : TELNET, HTTP
  TFTP server IP  :
  TFTP retries    : 3
  TFTP timeout    : 10 s
  TFTP file path  : SFPMS_V1-7.bin
Compatibility    : OFF
-----
CX_CM>
```

Figure 5.6 Example Configuration of Master modem in Fixed Rate Mode (Telnet)

SFP-Modem#2:

```
192.168.0.2 - Tera Term VT
Datei Bearbeiten Einstellungen Steuerung Fenster Hilfe
-----
Configuration
-----
Copper settings
  Mode           : SLAVE
  Copper Baserate : 157                10.000 Mbps
System settings
  IP address      : 192.168.0.2        MAC address 00:0F:D9:00:22:33
  Subnet mask     : 255.255.255.0
  Default gateway : 192.168.0.254
  Speed           : AUTO
  Flow control    : OFF
Services         : TELNET, HTTP
  TFTP server IP  : 192.168.0.14
  TFTP retries    : 3
  TFTP timeout    : 10 s
  TFTP file path  : SFPMS_V1-7.bin
Compatibility    : OFF
-----
CX_CM>
```

Figure 5.7 Example Configuration of Slave modem in Fixed Rate Mode (Telnet)

Configuring Fixed Rate Mode via WEB

SFP-Modem#1:

1. Enter to SFP-Modem#1 via WEB, then configure the following parameters in CONFIGURATION screen and click **Save** button:

The screenshot shows the 'Configuration' page for SFP-Modem#1. On the left is a navigation menu with 'CONFIGURATION' selected. The main area is divided into several sections: 'Network' with fields for IP address (192.168.0.1), Subnet mask (255.255.255.0), Gateway (192.168.0.254), Speed (1000F), and Flow control (checked); 'Copper wire' with Mode (MASTER) and Baserate (157 10 Mbps); 'Services' with Telnet and HTTP checked; 'TFTP' with Server IP, Retries (3), Timeout (10), and SW file path (SFPMS_V1-7.bin); and 'Compatibility' with Mode (OFF). A 'Save' button is at the bottom. A red callout box highlights the IP address, netmask, and gateway fields with the text: 'The IP address, netmask and gateway shown here are for example only.'

Figure 5.8 Configuring of Master modem in Fixed Rate Mode (WEB)

2. Click **Apply** button:

This screenshot is identical to Figure 5.8, but the 'Apply' button is highlighted with a green box. At the bottom of the page, a red banner contains the message: 'DEVICE CONFIGURATION WAS UPDATED BUT NOT ACTIVATED YET. PRESS "APPLY" BUTTON TO ACTIVATE IT NOW.'

Figure 5.9 Applying of the configuration (WEB)

3. The SFP modem will restart and the WEB-page will become unavailable. Because IP address, netmask and gateway of the SFP-Modem#1 were changed, it might be necessary to change the settings of the Host#1 to access SFP-Modem#1 again.

SFP-Modem#2:

1. Enter to SFP-Modem#2 via WEB, then configure the following parameters in CONFIGURATION screen and click **Save** button:

Figure 5.10 Configuring of Slave modem in Fixed Rate Mode (WEB)

2. Click **Apply** button:

SUMMARY STATUS CONFIGURATION MISCELLANEOUS COMMAND REFERENCE	Configuration	
	Network	
	IP address:	<input type="text" value="192.168.0.2"/>
	Subnet mask:	<input type="text" value="255.255.255.0"/>
	Gateway:	<input type="text" value="192.168.0.254"/>
Speed:	<input type="text" value="1000F"/>	
Flow control	<input type="checkbox"/>	
Services		Copper wire
Telnet	<input checked="" type="checkbox"/>	Mode: <input type="text" value="SLAVE"/>
HTTP	<input checked="" type="checkbox"/>	Baserate: <input type="text" value="157"/> 10 Mbps
TFTP		
Server IP:	<input type="text"/>	
Retries:	<input type="text" value="3"/>	
Timeout:	<input type="text" value="10"/>	
SW file path:	<input type="text" value="SFPMS_V1-7.bin"/>	
Compatibility		
Mode:	<input type="text" value="OFF"/>	
<input type="button" value="Save"/>		<input type="button" value="Apply"/>
DEVICE CONFIGURATION WAS UPDATED BUT NOT ACTIVATED YET. PRESS "APPLY" BUTTON TO ACTIVATE IT NOW.		

Figure 5.11 Applying of the configuration (WEB)

- The SFP modem will restart and the WEB-page will become unavailable. Because IP address, netmask and gateway of the SFP-Modem#2 were changed, it might be necessary to change the settings of the Host#2 to access SFP-Modem#2 again.

You can check the configuration after re-establishing of WEB connection to the SFP modems:

SFP-Modem#1:

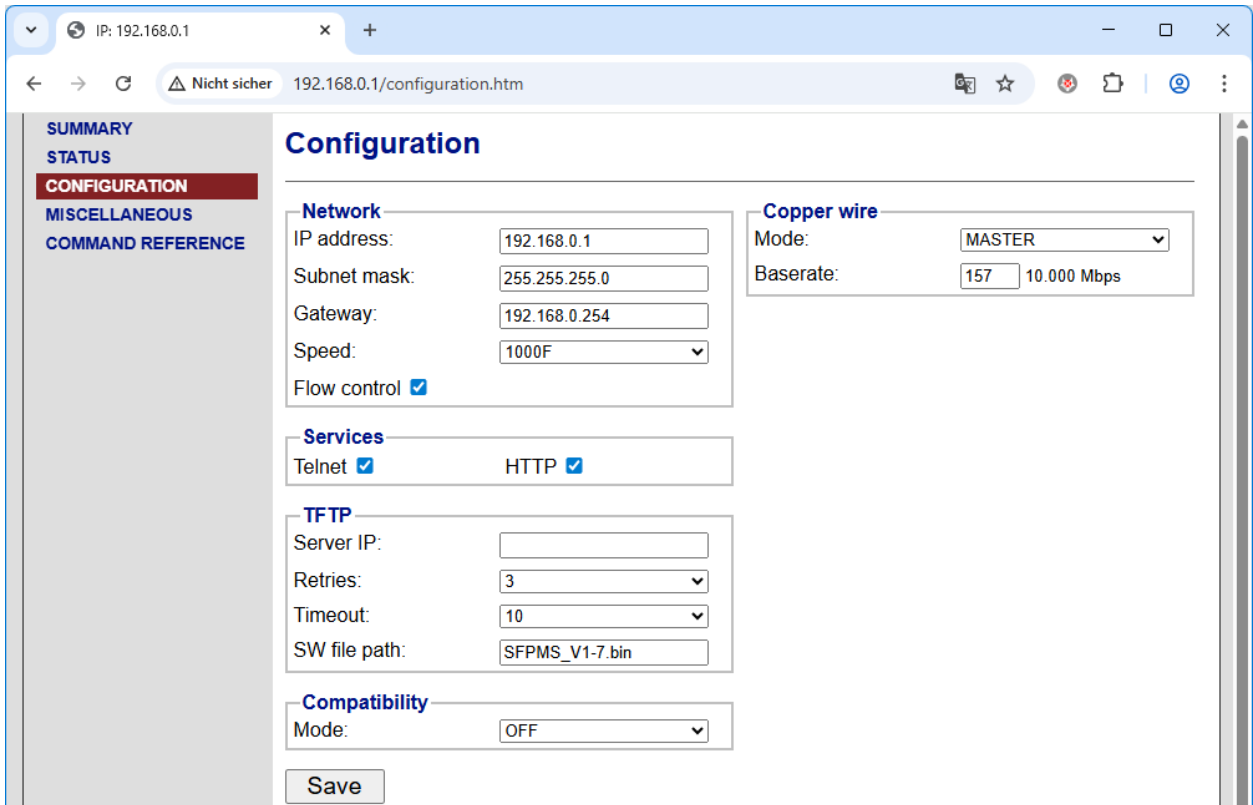

Figure 5.12 Example Configuration of Master modem in Fixed Rate Mode (WEB)

SFP-Modem#2:

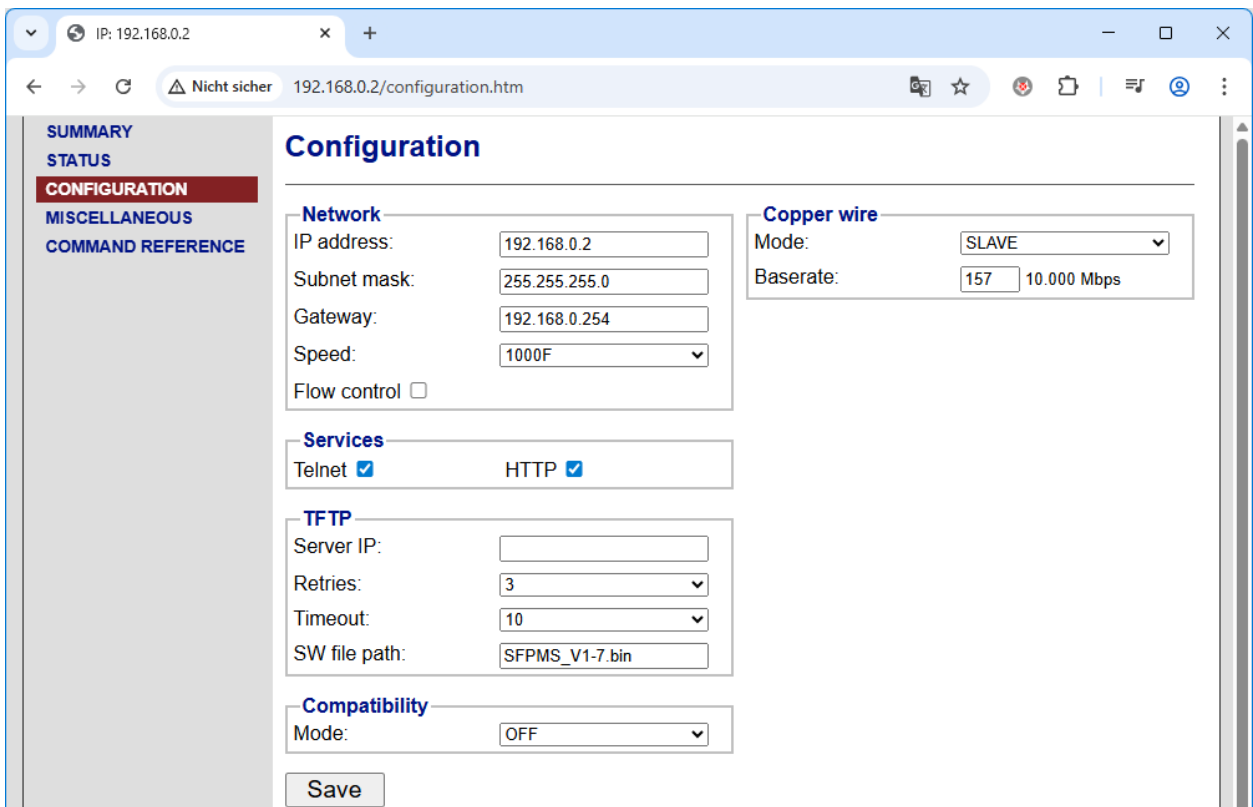

Figure 5.13 Example Configuration of Slave modem in Fixed Rate Mode (WEB)

Configuring Auto Rate Mode via Telnet

SFP-Modem#1: Enter to SFP-Modem#1 with Telnet then perform the following commands:
(The IP address, netmask and gateway shown here are for example purposes only)

Type following commands	Description
<↓>	Enter the Main Menu
3 <↓>	Go to Configuration Management (CM)
<MASTER ON> <↓>	Configure modem as Master
<BASERATE AUTO> <↓>	Set Auto Rate Mode
<SETIP 192.168.0.184> <↓>	Set the IP-address of the modem
<NETMASK 255.255.255.0> <↓>	Set the subnet mask
<GATEWAY 192.168.0.254> <↓>	Set the default gateway
<APPLY> <↓>	Apply and save all configurations (the SFP will restart and the Telnet connection will be closed)

Table 5.4 Initial configuring of Master modem in Auto Rate Mode (Telnet)

Because IP address, netmask and gateway of the SFP-Modem#1 were changed, it might be necessary to change the settings of the Host#1 to access SFP-Modem#1 again.

SFP-Modem#2: Enter to SFP-Modem#2 with Telnet then perform the following commands:
(The IP address, netmask and gateway shown here are for example purposes only)

Type following commands	Description
<↓>	Enter the Main Menu
3 <↓>	Go to Configuration Management (CM)
<MASTER OFF> <↓>	Configure modem as Slave
<BASERATE AUTO> <↓>	Set Auto Rate Mode
<SETIP 192.168.0.183> <↓>	Set the IP-address of the modem
<NETMASK 255.255.255.0> <↓>	Set the subnet mask
<GATEWAY 192.168.0.254> <↓>	Set the default gateway
<APPLY> <↓>	Apply and save all configurations (the SFP will restart and the Telnet connection will be closed)

Table 5.5 Initial configuring of Slave modem in Auto Rate Mode (Telnet)

Because IP address, netmask and gateway of the SFP-Modem#2 were changed, it might be necessary to change the settings of the Host#2 to access SFP-Modem#2 again.

You can check the configuration after re-establishing of Telnet connection to the SFP modems:

In Menu Configuration Management (CM) of the SFP modem, you can type NETCONFIG to check the configuration.

SFP-Modem#1:

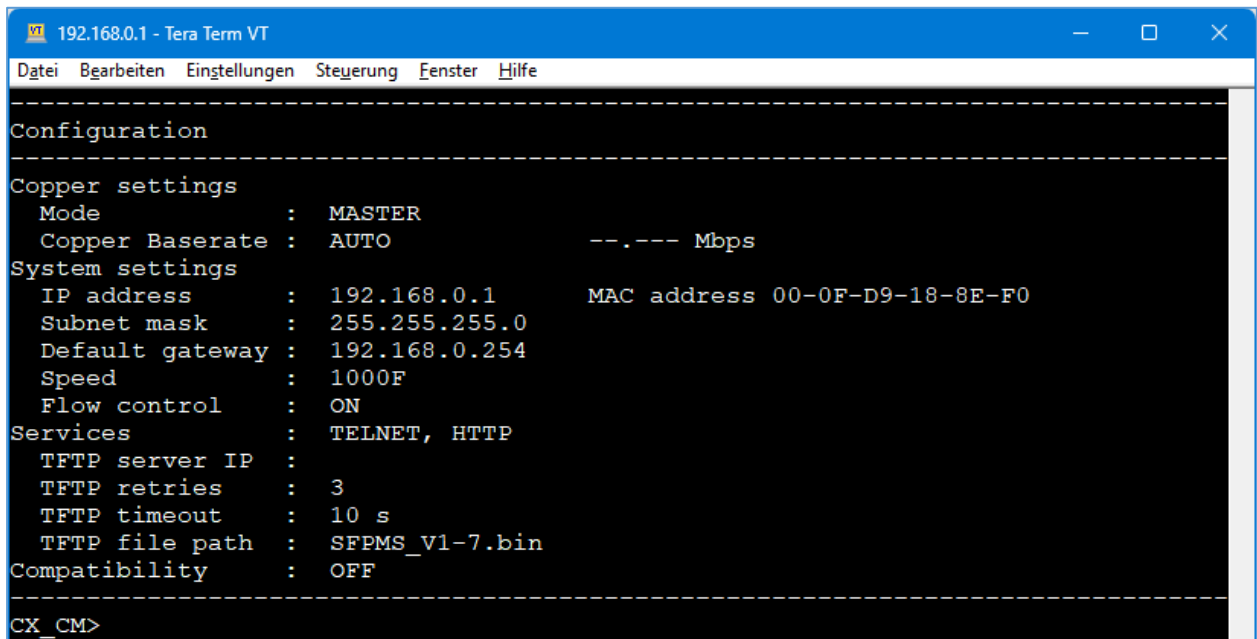

```
192.168.0.1 - Tera Term VT
Datei Bearbeiten Einstellungen Steuerung Fenster Hilfe
-----
Configuration
-----
Copper settings
Mode           : MASTER
Copper Baserate : AUTO           --.--- Mbps
System settings
IP address     : 192.168.0.1       MAC address 00-0F-D9-18-8E-F0
Subnet mask    : 255.255.255.0
Default gateway : 192.168.0.254
Speed         : 1000F
Flow control   : ON
Services       : TELNET, HTTP
TFTP server IP :
TFTP retries   : 3
TFTP timeout   : 10 s
TFTP file path : SFPMS_V1-7.bin
Compatibility  : OFF
-----
CX_CM>
```

Figure 5.14 Example Configuration of Master modem in Auto Rate Mode (Telnet)

SFP-Modem#2:

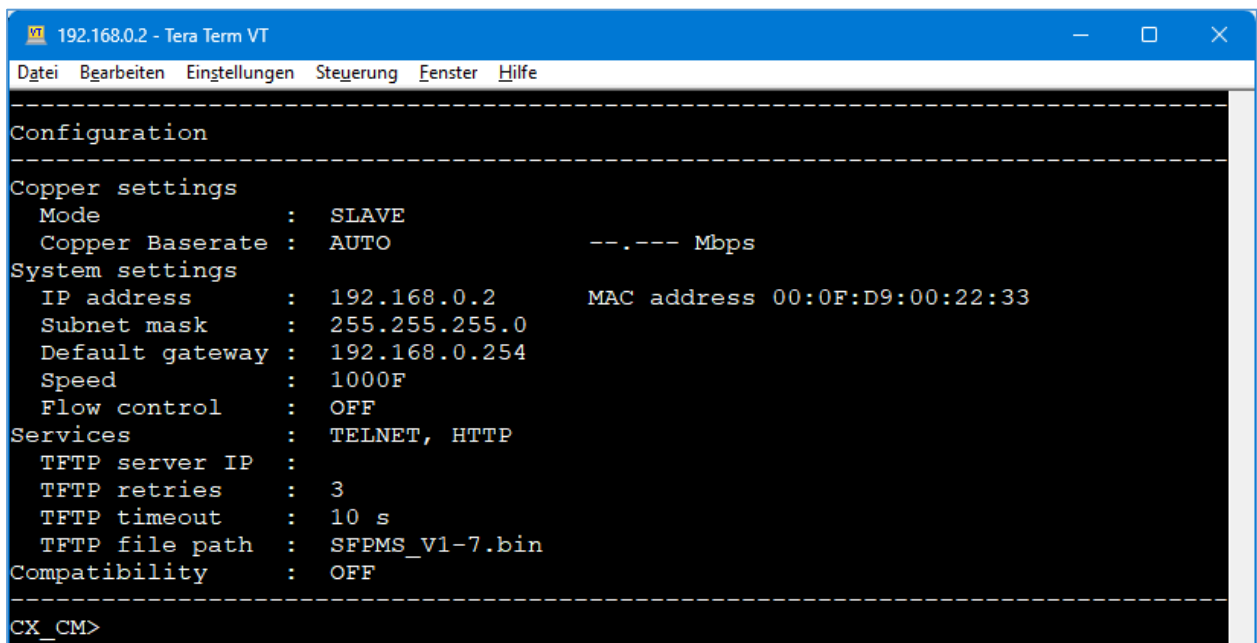

```
192.168.0.2 - Tera Term VT
Datei Bearbeiten Einstellungen Steuerung Fenster Hilfe
-----
Configuration
-----
Copper settings
Mode           : SLAVE
Copper Baserate : AUTO           --.--- Mbps
System settings
IP address     : 192.168.0.2       MAC address 00:0F:D9:00:22:33
Subnet mask    : 255.255.255.0
Default gateway : 192.168.0.254
Speed         : 1000F
Flow control   : OFF
Services       : TELNET, HTTP
TFTP server IP :
TFTP retries   : 3
TFTP timeout   : 10 s
TFTP file path : SFPMS_V1-7.bin
Compatibility  : OFF
-----
CX_CM>
```

Figure 5.15 Example Configuration of Slave modem in Auto Rate Mode (Telnet)

Configuring Auto Rate Mode via WEB

SFP-Modem#1:

4. Enter to SFP-Modem#1 via WEB, then configure the following parameters in CONFIGURATION screen and click **Save** button:

The screenshot shows the 'Configuration' page for SFP-Modem#1. On the left is a navigation menu with 'CONFIGURATION' selected. The main area is divided into several sections: 'Network' with fields for IP address (192.168.0.1), Subnet mask (255.255.255.0), Gateway (192.168.0.254), Speed (1000F), and Flow control (checked); 'Copper wire' with Mode (MASTER) and Baserate (AUTO); 'Services' with Telnet and HTTP checked; 'TFTP' with Server IP, Retries (3), Timeout (10), and SW file path (SFPMS_V1-7.bin); and 'Compatibility' with Mode (OFF). A 'Save' button is at the bottom. A red-bordered box highlights the IP, netmask, and gateway fields with the text: 'The IP address, netmask and gateway shown here are for example only.'

Figure 5.16 Configuring of Master modem in Auto Rate Mode (WEB)

5. Click **Apply** button:

This screenshot is identical to Figure 5.16, but the 'Apply' button is highlighted with a green border. At the bottom of the page, a red banner contains the message: 'DEVICE CONFIGURATION WAS UPDATED BUT NOT ACTIVATED YET. PRESS "APPLY" BUTTON TO ACTIVATE IT NOW.'

Figure 5.17 Applying of the configuration (WEB)

- The SFP modem will restart and the WEB-page will become unavailable. Because IP address, netmask and gateway of the SFP-Modem#1 were changed, it might be necessary to change the settings of the Host#1 to access SFP-Modem#1 again.

SFP-Modem#2:

- Enter to SFP-Modem#2 via WEB, then configure the following parameters in CONFIGURATION screen and click **Save** button:

Figure 5.18 Configuring of Slave modem in Auto Rate Mode (WEB)

- Click **Apply** button:

SUMMARY

STATUS

CONFIGURATION

MISCELLANEOUS

COMMAND REFERENCE

Configuration

Network

IP address:

Subnet mask:

Gateway:

Speed:

Flow control

Copper wire

Mode:

Baserate:

Services

Telnet HTTP

TFTP

Server IP:

Retries:

Timeout:

SW file path:

Compatibility

Mode:

DEVICE CONFIGURATION WAS UPDATED BUT NOT ACTIVATED YET. PRESS "APPLY" BUTTON TO ACTIVATE IT NOW.

Figure 5.19 Applying of the configuration (WEB)

6. The SFP modem will restart and the WEB-page will become unavailable. Because IP address, netmask and gateway of the SFP-Modem#2 were changed, it might be necessary to change the settings of the Host#2 to access SFP-Modem#2 again.

You can check the configuration after re-establishing of WEB connection to the SFP modems:

SFP-Modem#1:

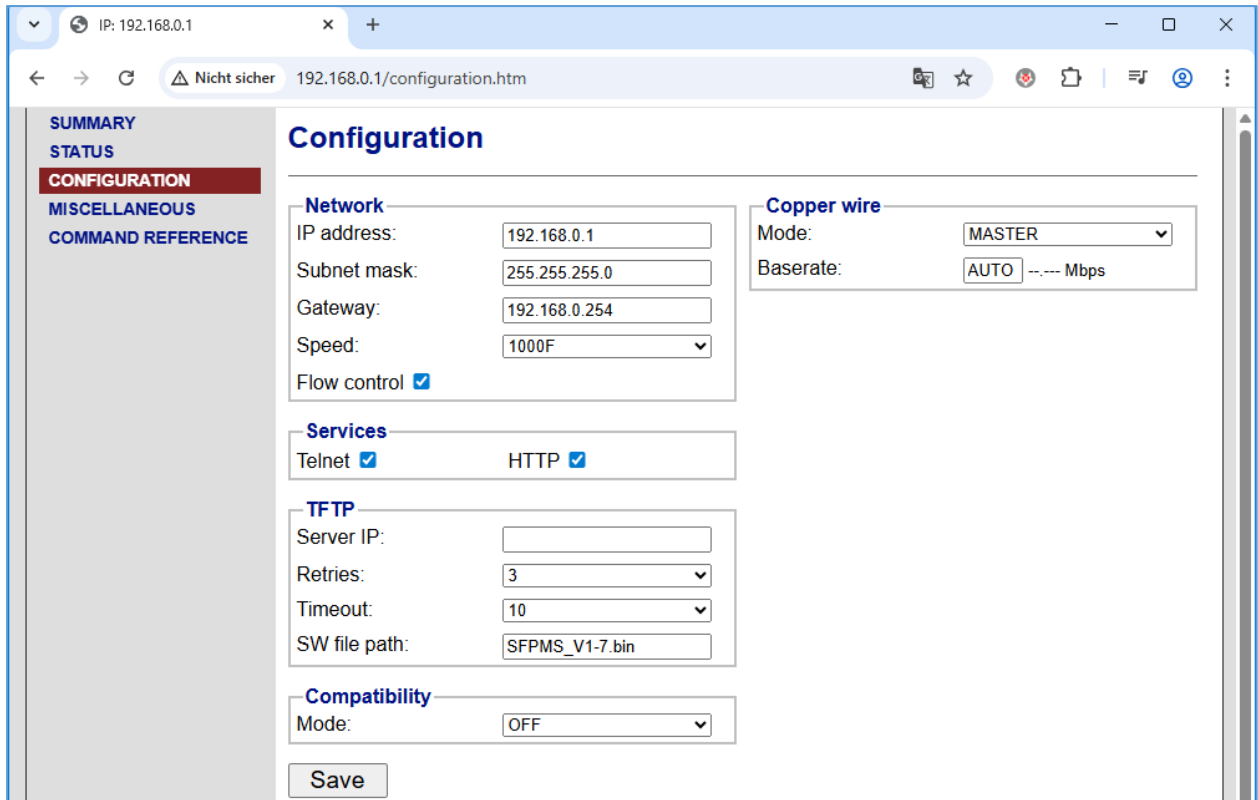

Figure 5.20 Example Configuration of Master modem in Auto Rate Mode (WEB)

SFP-Modem#2:

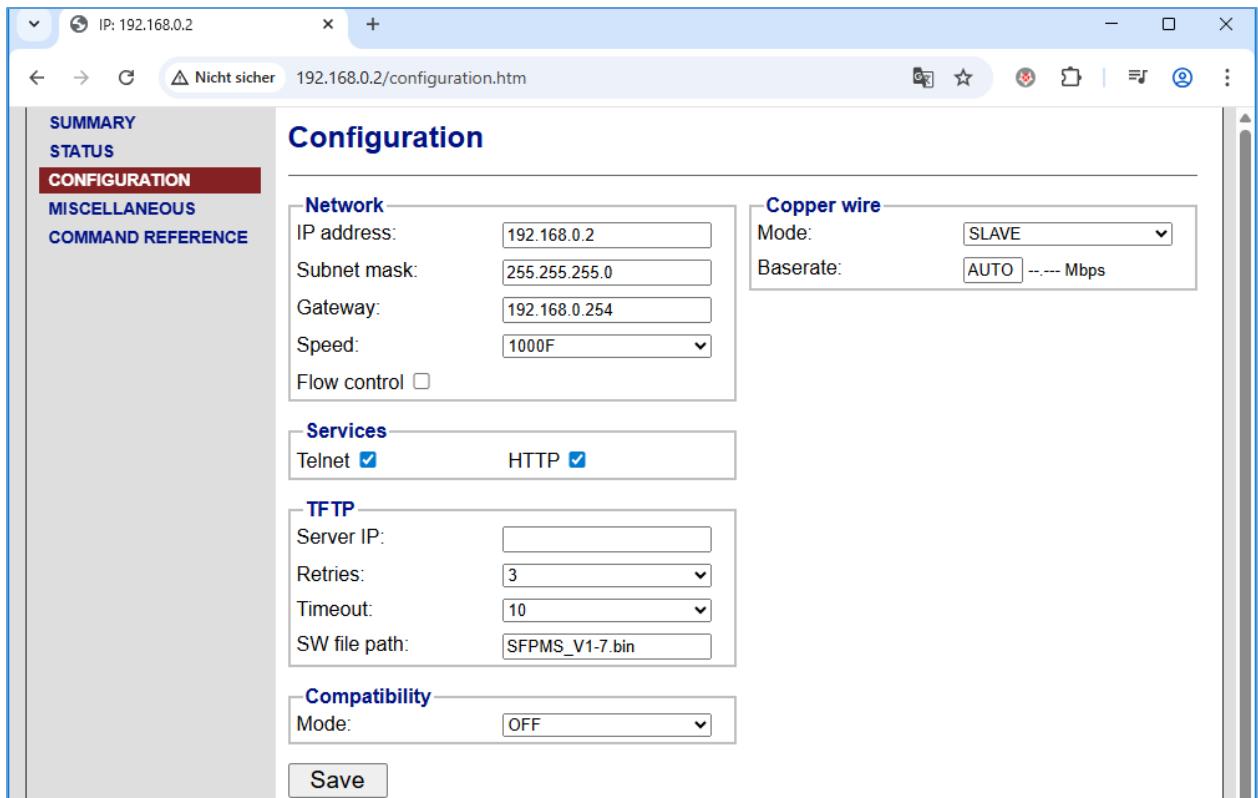

Figure 5.21 Example Configuration of Slave modem in Auto Rate Mode (WEB)

5.4 Checking of Link Quality and Baserate adjustment

ATTENTION



- In **Fixed Rate** mode the link is established in 2..10 seconds if line parameters allow it.
- Depending on the line parameters, in **Auto Rate** mode it may take from 30 seconds to 3 minutes to establish a link.

The better the line parameters, the faster the connection will be established.

1. After link establishing, check the transmission status of the devices. To do this, enter the STATUS command in the second menu of the Telnet session or switch to the Status screen in the WEB interface:

```
192.168.0.184 - Tera Term VT
File Edit Setup Control Window Help
-----
Status
-----
Mode:      master
Baserate:  144          9.216 Mbps
SNR:       21.50 dB    good
LAN / FC:  100F / on

Voltage:   3.293 V
Temperature: 44.15 C
Software:  ok

SFP Switch: normal
-----
CX_FMM>
```

Figure 5.22 STATUS command (Telnet)

SUMMARY	
STATUS	Status
CONFIGURATION	
MISCELLANEOUS	
COMMAND REFERENCE	

Mode:	slave
Baserate:	144 9.216 Mbps
SNR:	23.50 good
LAN / FC:	100F / on
Voltage:	3.291 V
Temperature:	44.96 °C
SW:	ok
SFP Switch:	normal

Figure 5.23 Status screen (WEB)

2. Check if the SNR value is at least 20.5 and the link quality indicates “good”.
 - If SNR is less than 20.5 and connection quality indicates "marginal" or "poor" on either Master or Slave side, then decrease connection Baserate by 10%. Wait until connection is established, then check Status again.

- If SNR is constantly greater than 23 on both, Master and Slave sides, you may try to increase the Baserate on 10%. Wait until connection is established, then check Status again. If the link quality is not “good”, then return to the previously achieved Baserate.
3. **After the optimal Baserate is reached, at which the link quality is stably "good", it is recommended set a fixed Baserate for both, Master and Slave modem.** This will allow modems in the future to quickly restore the link in case of connection loss.

5.5 Approximate transmission range

The real transmission distance may differ from the data in the table below, because of:

- noisy environment or multipair cable with additional disruptive services
- differences in cable values (bandwidth, crosstalk etc), just same diameter
- bad installation, cables are not twisted, not using a paired cable

Cable Type	Wire Diameter	Distance (Meter) @ speed:					
		1536 kbps	4352 kbps	7168 kbps	10000 kbps	14016 kbps	18048 kbps
Cable U72 (installation cable)	0.4mm, AWG-26	1600	1100	950	800	650	450
Cable U72 (installation cable)	0.5mm, AWG-24	2100	1400	1100	950	750	500
Cable U72 (installation cable)	0.8mm, AWG-20	3800	2500	2100	1800	1400	1000
Siemens 6XV1830-5EH10 (PROFIBUS cable)	1.0mm, AWG-18	6200	4100	3400	2900	2300	1600

Table 5.6 Baserate settings and transmission Data Rate

5.6 Problem with Xentino VS86P/VS86I SFP Copper Wire Modem

If you have a problem with the **Xentino VS86P/VS86I** SFP modems, please send following details to your Xentino contact:

- Application Description
- Main Menu picture (Telnet session) or SUMMARY screen (WEB interface) of every modem
- Configuration and status of every modem: perform the SFPVIEW command and save its output into txt-file

6 Technical Description

6.1 Description of Xentino VS86P/VS86I SFP Copper Wire Modem

The **Xentino VS86P/VS86I** Copper Wire modems are available as a Small Form-factor Pluggable (SFP) device. There are two models with different line connectors (see also Selection Guide):

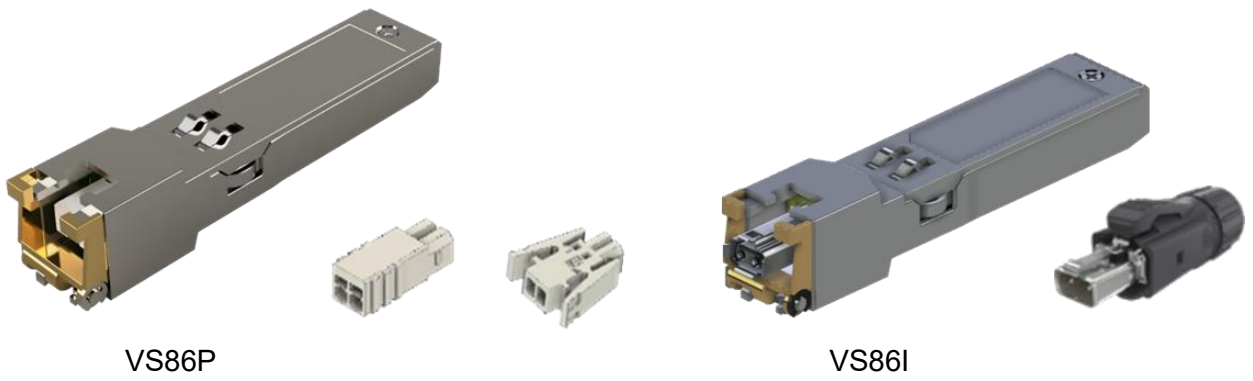

Figure 6.1 Xentino VS86P/VS86I SFP Copper Wire modem

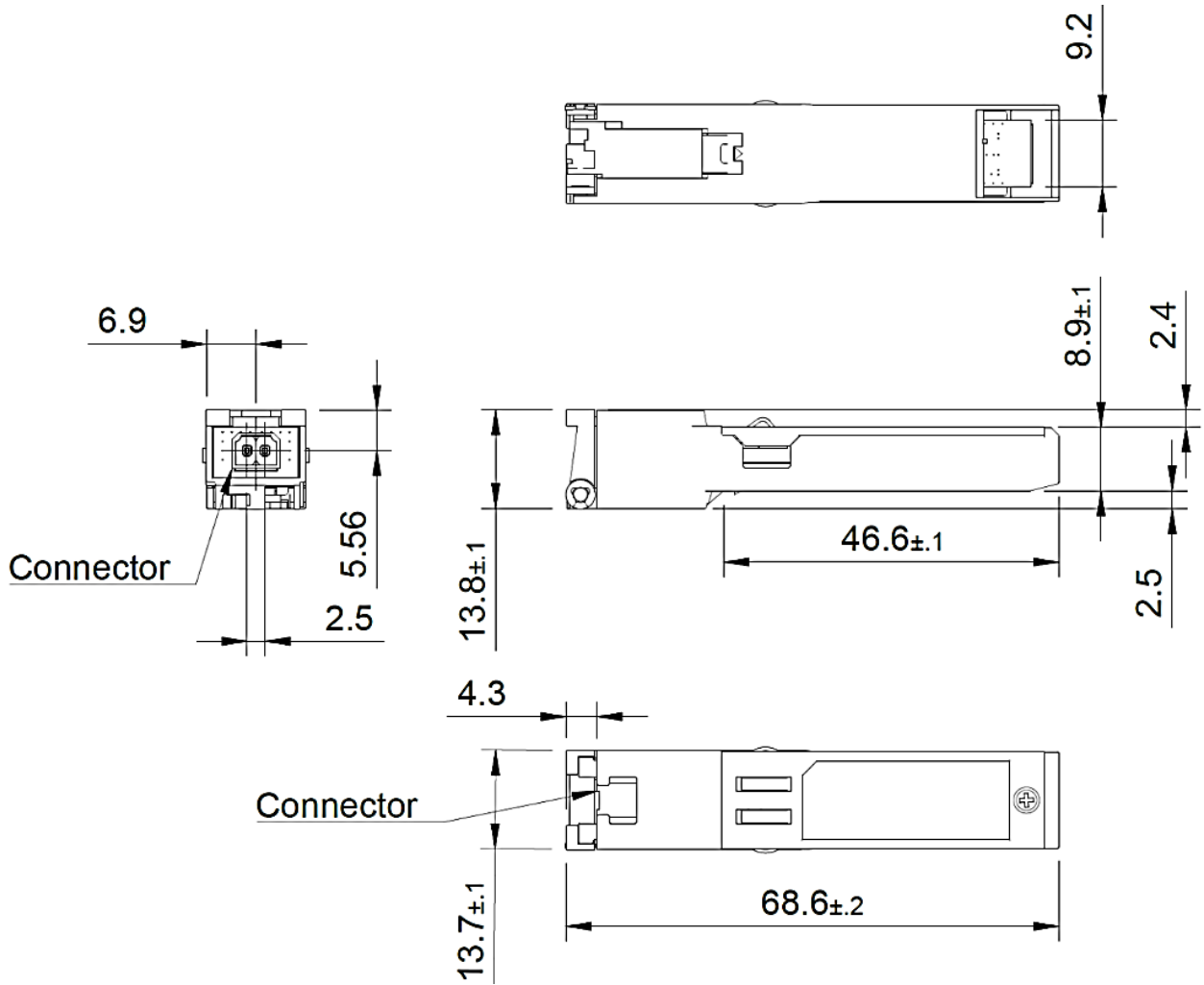

Figure 6.2 VS86P Dimensions

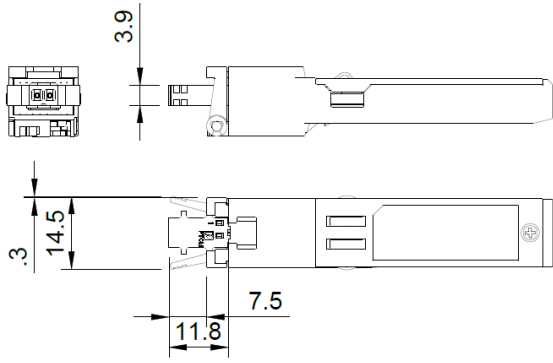

Figure 6.3 VS86P with Connector 1015464

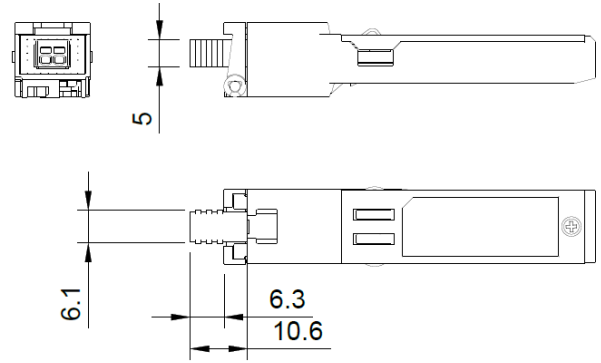

Figure 6.4 VS86I with Connector 1704853

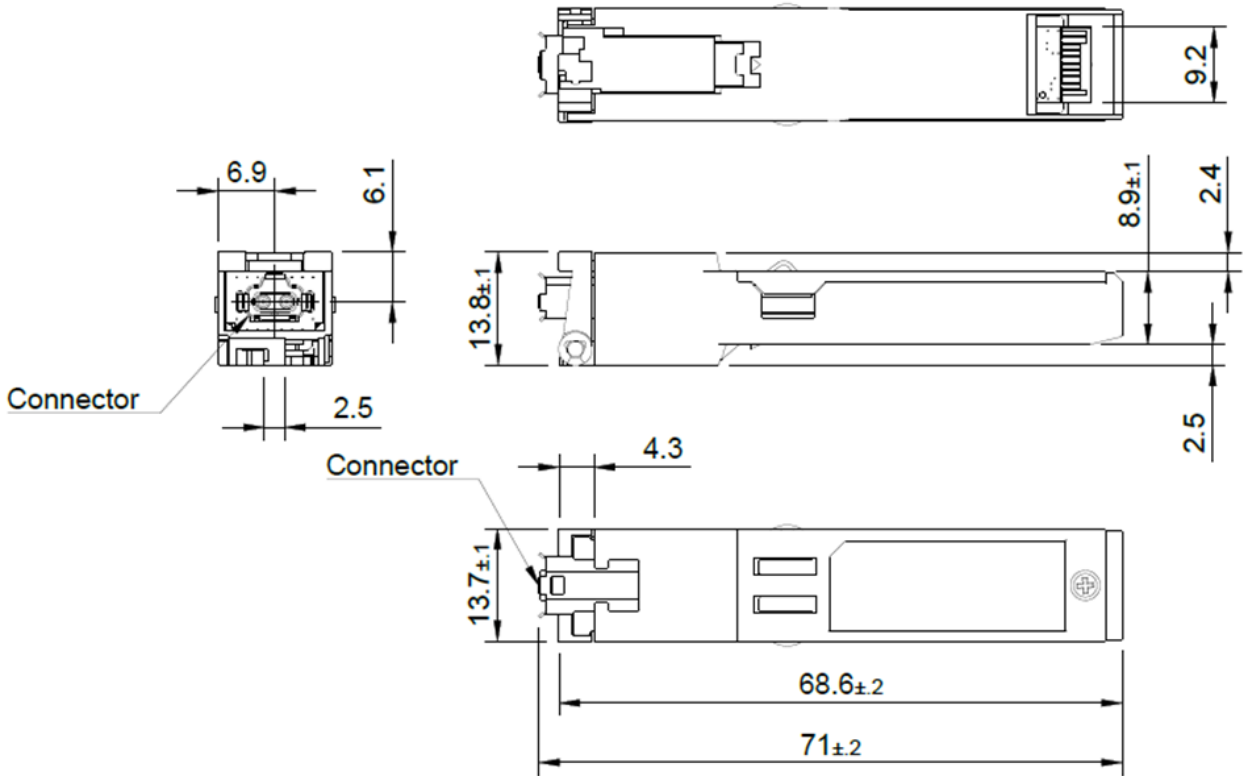

Figure 6.5 VS86I Dimensions

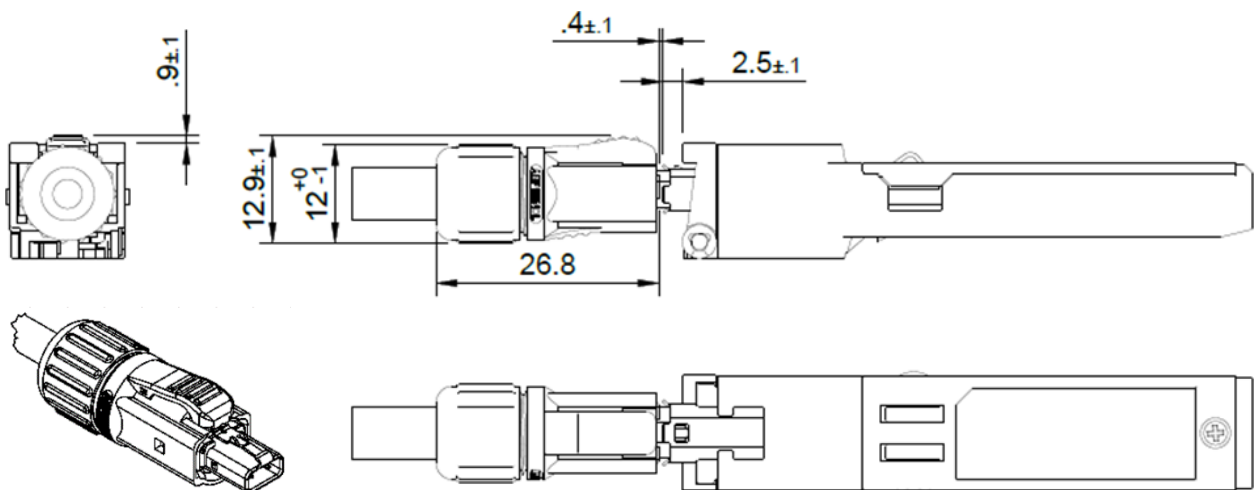

Figure 6.6 VS86I with Connector MSPE-P2L0-2A0XX

6.2 Interface Description

Copper Wire modem Interface

The **Xentino VS86P/VS86I** SFP modem has a single modem interface that provides full-duplex connectivity at speeds in the range of 1536..18048 kbps over a pair of copper wires. The transmission speed is defined by Baserate parameter and can be selected with the steps of 64kbps. To select the Transmission Rate, use the BASERATE command in Telnet or set the Baserate parameter on the WEB interface Configuration screen.

Baserate	Transmission Data Rate
24..282	Baserate*64kbps=1536..18048kbps

Table 6.1 Baserate settings and transmission Data Rate

The **Xentino VS86P/VS86I** SFP modem uses the Pulse Amplitude Modulation (PAM) technology.

Master/Slave

To establish a connection, it is necessary that one SFP modem is configured as Master and the other as Slave. In this case, the connection is controlled by the Master modem.

In case both modems are set to the same mode, the mode of one modem might be changed automatically during handshake process. Despite this, it is recommended to set one modem to Master mode and the other to Slave mode, as this will reduce the connection establishment time.

The Factory Default setting is Master.

Fixed and Auto Rate Modes

The **Xentino VS86P/VS86I** SFP modems can operate in Fixed and Auto Rate Modes.

Fixed Rate Mode

The SFP modem will operate in Fixed Rate Mode if the Baserate parameter is set as an integer from the range 24..282. In this case, the modem will primarily try to establish a connection at a speed of Baserate*64 kbps.

If both SFP modems are in Fixed Rate Mode with the same Baserate, then establishing a connection usually takes within 2..10 seconds. The line parameters must allow link establishing with the specified Baserate, otherwise the communication will not be established.

If both modems are set to Fixed Rate Mode, but with different Baserate, then the communication will not be established.

Auto Rate Mode

The Auto Rate Mode is activated by setting Baserate parameter to AUTO.

If both modems in a link are set to Auto Rate Mode, the connection will be established at the highest possible speed that will ensure a stable connection.

If Master modem is set to Fixed Rate Mode and the Slave is set to Auto Rate Mode, the connection rate will be defined by the Master modem. However, line parameters must allow link establishing with the specified Baserate, otherwise the communication will not be established.

If Master modem is set to Auto Rate Mode then the Slave modem must be set to Auto Rate too.

Using of Auto Rate Mode will increase the link establishing time; depending on the line parameters

it may take from 30 seconds to 3 minutes.

The Factory Default setting is Auto Rate Mode.

Link Quality Monitoring

The Signal to Noise Ratio (SNR) provides qualitative performance information of a specific link and can be used during installation and maintenance procedures. The SNR value and link quality indicator are shown by STATUS command in the Telnet session or on the Status screen in the WEB interface:

```
CX_FMM>STATUS
-----
Status
-----
Mode:          slave
Baserate:     144          9.216  Mbps
SNR:          22.00  dB    good
LAN / FC:     100F / on

Voltage:      3.292 V
Temperature:  44.68 C
Software:     ok

SFP Switch:   normal
-----
CX_FMM>
```

Figure 6.7 SNR value and link quality indicator (STATUS command, Telnet session)

SUMMARY	Status
STATUS	
CONFIGURATION	
MISCELLANEOUS	
COMMAND REFERENCE	
Mode:	master
Baserate:	282 18.048 Mbps
SNR:	26.00 good
LAN / FC:	100F / on
Voltage:	3.308 V
Temperature:	67.53 °C
SW:	ok
SFP Switch:	normal

Figure 6.8 SNR value and link quality indicator (Status screen, WEB interface)

During acceptance testing, it is recommended to set the line rate or choose cable pairs (at a fixed line rate) so that the SNR value is at least 20.5 dB (link quality must indicate “good”).

Fast Link Recovery

In case of link interruption , the device will first try to re-establish the connection using the internal settings of the copper transceiver with which the previous connection was established. Thus, in case of short, less than 2 seconds, transmission losses caused by such phenomena as over voltage spikes, short interruptions or short cuts caused by over voltage protection, the connection will be re-established in 2..10 seconds, without using the full handshake procedure.

If the fast link recovery fails, device will reset the parameters of the copper interface and start a

new handshake procedure, according to device configuration settings.

Please refer to the Table 5.1 in Chapter 1790025614.2011183570.

Automatic Active Remote Device Detection

The SFP modem automatically detects the presence of an active device on the remote side of the line. If there is another active SFP modem on the remote side, the SFP modem starts the handshake procedure.

If the SFP modem cannot detect the presence of an active remote device, it will wait until to appear, and a cable problem message will be displayed on the STATUS command in the Telnet session or on the Status screen of the WEB interface:

SUMMARY	Status
STATUS	
CONFIGURATION	
MISCELLANEOUS	
COMMAND REFERENCE	
Mode:	cable problem
Baserate:	--- --- Mbps
SNR:	--- ---
LAN / FC:	100F / on
Voltage:	3.291 V
Temperature:	44.34 °C
SW:	ok
SFP Switch:	normal

Figure 6.9 Cable problem message (Status screen, WEB interface)

The appearance of the "cable problem" message may mean:

- cable break
- short circuit in the cable
- remote module is not connected to the line
- no power supply to the remote module
- too much resistance (length) of the cable

Ethernet Interface (SFP Host Interface)

The Ethernet interface of **Xentino VS86P/VS86I** SFP modem fulfil the standard IEEE 802.3. The SFP supports operation in any 100BASE-FX or 1000BASE-X Host Equipment (Switch, Router etc.)

The SFP modem supports 100BASE-FX/1000BASE-X automatic adjustment.

The SFP Ethernet interface operates in a mixed (hybrid) mode, i.e., tagged and untagged traffic is allowed, which is transmitted over a copper link to the remote side. Only control packets (Telnet or WEB) intended for the internal microcontroller are switched to it by the internal switch.

Alarm Description

The alarm status is indicated in the Main Menu of the Telnet session and on the Summary screen of the WEB interface:

```
MODEL COPSFPMPSPAM
HW 01AA
SW 1.9
DATE 17-11-2025
RUNS 0d 00:15:49
ALARM NOT URGENT (SW)
MODEL_DESC Xentino SFP/100BASE-FX 1000BASE-X/Copper 1.536-18.048 Mbps
IP 192.168.0.1
MAC 00-0F-D9-18-8E-F0
```

Figure 6.10 Alarm status string in the Main Menu (Telnet session)

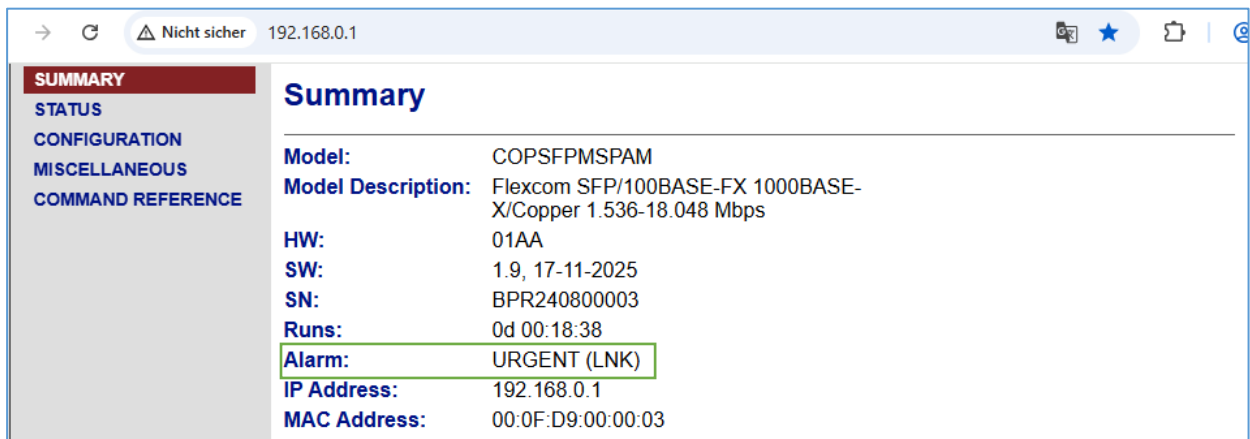

Figure 6.11 Alarm status string on the Summary screen (WEB interface)

Name	Alarm status	Description
SW	Non-urgent	One of the software banks is not programmed
LNK	Urgent	Copper Wire link is not established

Table 6.2 Xentino VS86P/VS86I SFP modem Alarms

6.3 Management of Xentino VS86P/VS86I SFP Copper Wire Modem

The **Xentino VS86P/VS86I** SFP modems have integrated management and diagnostic functionality. The access to this functionality is possible via IP network by accessing over Telnet or by using the WEB interface.

The management and diagnostic functionality are used to configure the modems and to receive additional information like link quality.

For security purposes, you can disable Telnet and/or WEB access after configuring. If both, Telnet and WEB are disabled, then it will be necessary to reset the SFP modem to its factory settings to restore access . This can be done by using the switch, described in Chapter 5.1 above.

Default IP Address

The default IP address for the **Xentino VS86P/VS86I** SFP modem is 192.168.0.1.

Telnet

The **TELNET** (TELEcommunication NETwork) access is made through the Ethernet network. With any computer and a program with the Telnet protocol **Xentino VS86P/VS86I** SFP modems can be fully managed.

Open the Telnet session, press Enter and the modem main menu is displayed:

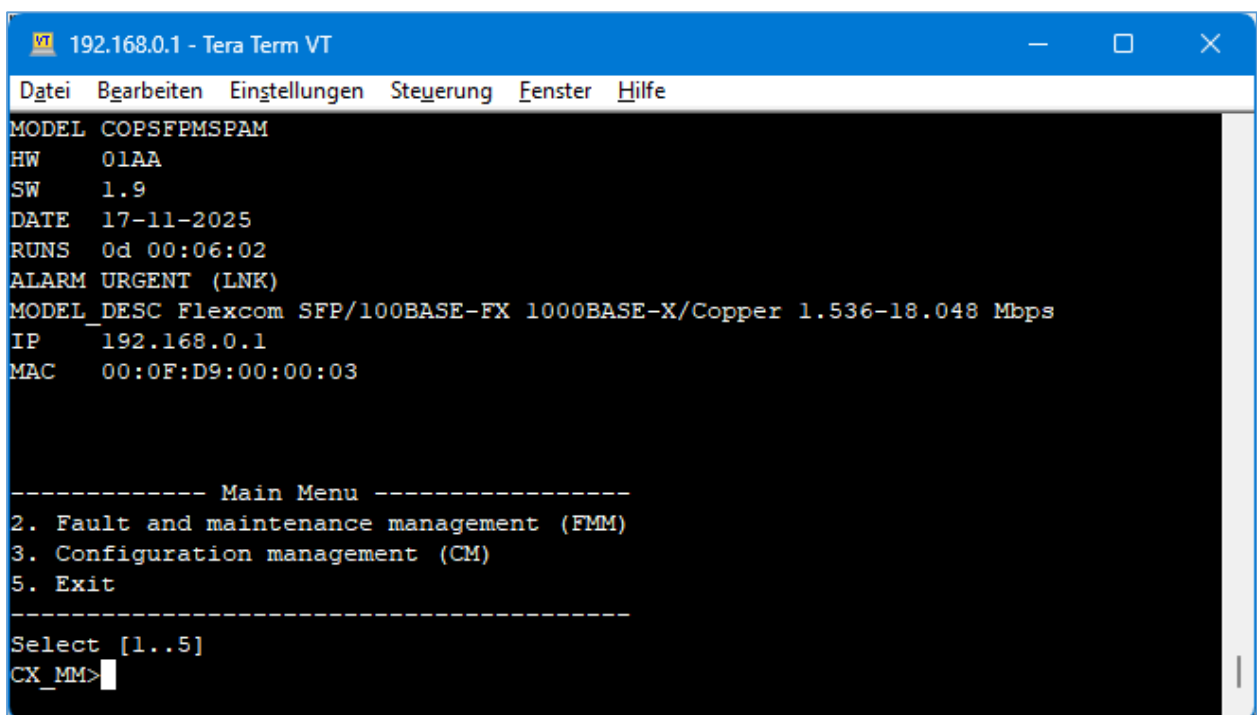

```
192.168.0.1 - Tera Term VT
Datei Bearbeiten Einstellungen Steuerung Fenster Hilfe
MODEL COPSFPMSPAM
HW 01AA
SW 1.9
DATE 17-11-2025
RUNS 0d 00:06:02
ALARM URGENT (LNK)
MODEL_DESC Flexcom SFP/100BASE-FX 1000BASE-X/Copper 1.536-18.048 Mbps
IP 192.168.0.1
MAC 00:0F:D9:00:00:03

----- Main Menu -----
2. Fault and maintenance management (FMM)
3. Configuration management (CM)
5. Exit
-----
Select [1..5]
CX_MM>
```

Figure 6.12 Main Menu (Telnet session)

If no symbols are received by the SFP modem over the telnet connection within 5 minutes, this session breaks.

WEB

The WEB interface is used to display status and to do configuration. Any WEB browser can be used to access the WEB interface. To enter SFP WEB interface, you should enter the command: **http://X.X.X.X** in the WEB browser. (X.X.X.X is the IP-address of the modem).

After the connection is established, the Summary screen appears and it is possible to check the status and/or change the configuration:

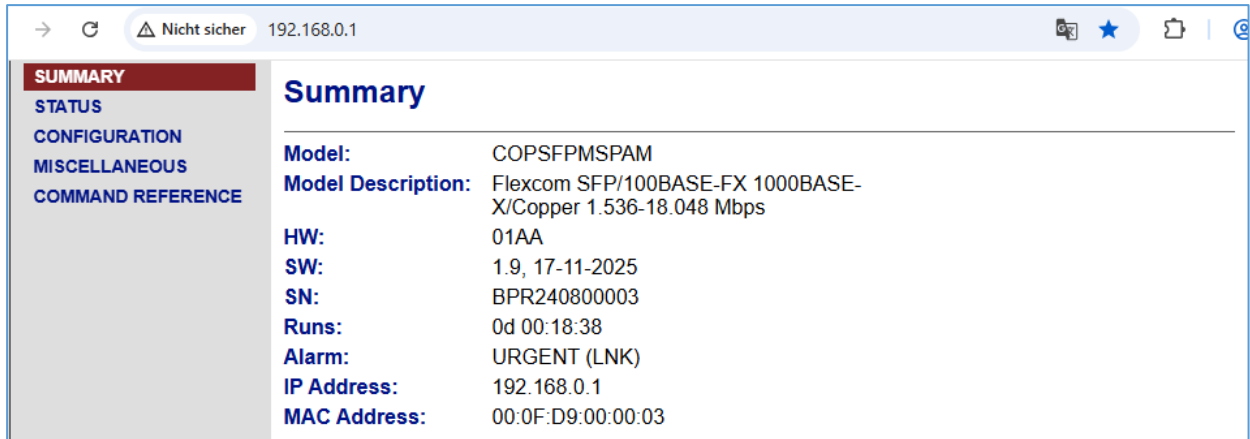

Figure 6.13 Summary screen (WEB interface)

The WEB interface has following tabs: Status, Configuration, Miscellaneous and Command Reference. Select in the left part of the window to display the necessary table.

The Status table is displayed dynamically and refreshed every 5 seconds:

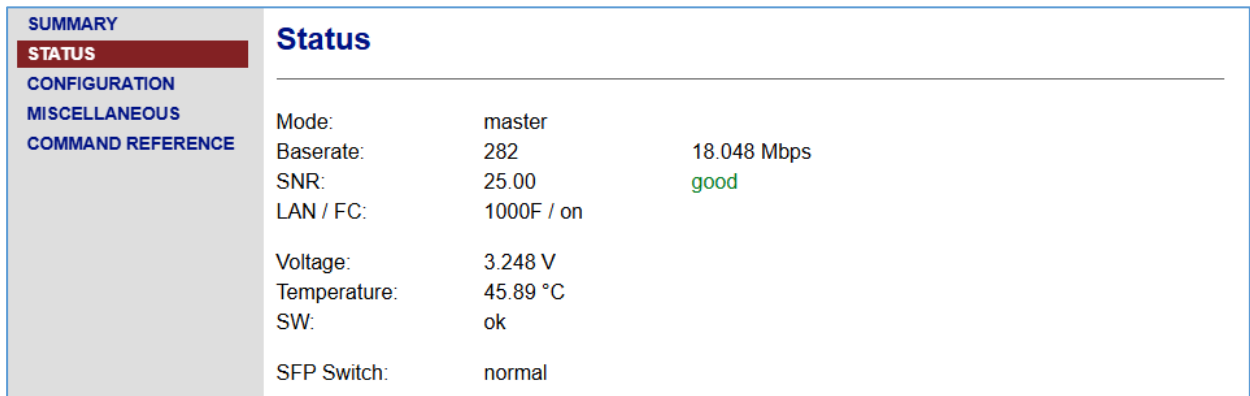

Figure 6.14 Status screen (WEB interface)

On the configuration screen, you will find the configuration options. If you need clarification on any setting, please refer to the Command Reference. After changing the configuration, you must press the **Save** button. To apply configuration changes and to store them, press the **Apply** button. SFP will restart with new configuration.

The screenshot shows the 'Configuration' page in a web interface. On the left is a sidebar with navigation links: SUMMARY, STATUS, CONFIGURATION (highlighted in red), MISCELLANEOUS, and COMMAND REFERENCE. The main content area is titled 'Configuration' and contains several sections:

- Network:** IP address (192.168.0.1), Subnet mask (255.255.255.0), Gateway (192.168.0.254), Speed (1000F), and Flow control (checked).
- Services:** Telnet (checked) and HTTP (checked).
- TFTP:** Server IP (empty), Retries (3), Timeout (10), and SW file path (SFPMS_V1-7.bin).
- Compatibility:** Mode (OFF).

At the bottom left of the main content area is a 'Save' button.

Figure 6.15 Configuration screen (WEB interface)

On the Miscellaneous screen you will find some important control possibilities like “Factory Default”, “Restart” and “TFTP SW Update” buttons. There is also a section for selecting an active software bank:

The screenshot shows the 'Miscellaneous' page in a web interface. On the left is a sidebar with navigation links: SUMMARY, STATUS, CONFIGURATION, MISCELLANEOUS (highlighted in red), and COMMAND REFERENCE. The main content area is titled 'Miscellaneous' and contains several sections:

- Controls:** Factory Default, Reset, and TFTP SW Update buttons.
- Selected Software:** Two radio buttons for software banks. The first is selected (radio button with a blue dot). Both banks have the same details: ver.: 1.9, date: 17-11-2025, length: 516096 bytes, CRC: 0x4f2c, fixed.
- User Management:** Password field and Set Password button.

Figure 6.16 Miscellaneous (WEB interface)

I2C

It's also possible to manage some parameters of the SFP over the Vendor Specific Control Register (reg 248-253, A2h). Please see the yellow marked fields in the [Diagnostic and Control/Status](#)

[Fields, Address A2h](#) chapter for further details. The values are adopted approx. 4 seconds after the last value was entered. The unit will reboot afterwards.

7 Diagnostic and Control/Status Fields Memory Map

The SFF-8472 R12.4 specification (Management Interface for SFP+) defines an enhanced memory map with a digital diagnostic monitoring (DDM) interface for SFP transceivers that allows pseudo real time access to device operating parameters. It defines a 256 bytes memory map which is accessible over a 2-wire serial interface at the 8-bit address 1010000X (A0h), the ID fields. The digital diagnostic monitoring interface makes use of the 8-bit address 1010001X (A2h).

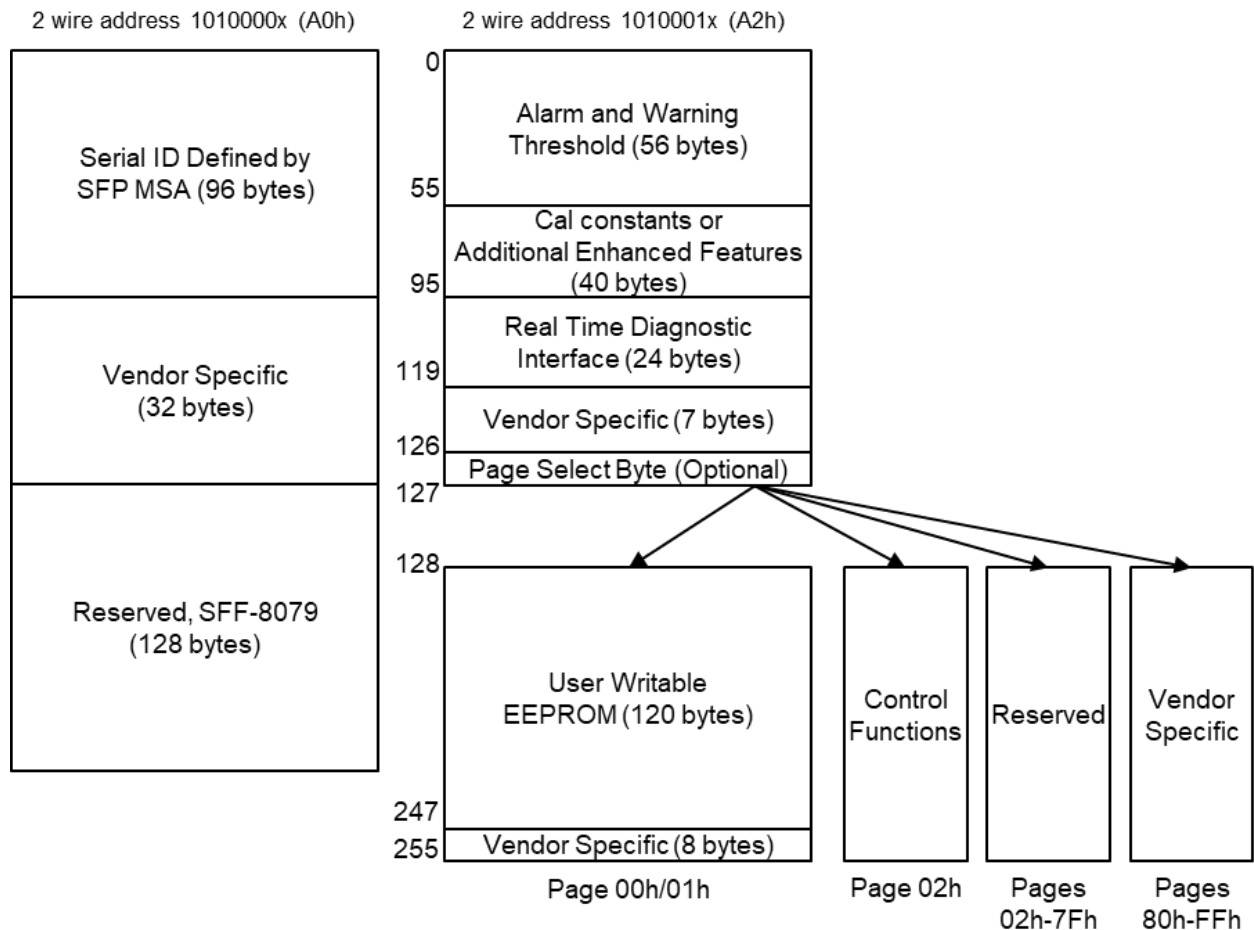

Figure 7.1 Digital Diagnostic Memory Map Specific Data Field Descriptions

7.1 Base/Extended ID Fields, Address A0h

Address	Name	Content (Hex)	Description
0	Identifier	03	SFP
1	Ext. Identifier	04	SFP function is defined by 2-wire interface ID
2	Connector	00	Unspecified
3-10	Transceiver	00 00 00 00 00 00 40 00	Twisted Pair (TP)
11	Encoding	00	Unspecified
12	Signaling Rate, Nominal	00	Unspecified
13	Rate Identifier	00	Unspecified
14-17	Link length fiber	00 00 00 00	
18	Length copper cable	C8	Minimum 200 meter
19	Supported length copper cable	FA	5800 meters
20-35	Vendor name	46 6C 65 78 44 53 4C 20 20 20 20 20 20 20 20 20	Xentino
36	Transceiver compliance	00	Not specified
37-39	Vendor OUI	00 0F D9	00 0F D9
40-55	Vendor PN	43 4F 50 53 46 50 4D 53 50 41 4D 20 20 20 20 20	COPSPFMSPAM
56-59	Vendor rev	31 2E 30 20	1.0
60-61	Wavelength	00 00	
62	Fiber Channel Speed 2	00	
63	CC_BASE	xx	Check code for Base ID Fields (addresses 0-62)
64-65	Options	00 12	TX_DISABLE and Loss of Signal implemented
66	Signaling Rate, max	00	Unspecified
67	Signaling Rate, min	00	Unspecified
68-83	Vendor Serial Number	xx	
84-91	Date code	yy yy mm mm dd dd 20 20	Year yy yy, Month: mm mm, Day: dd dd, Lot:
92	Diagnostic Monitoring Type	20	Internally calibrated
93	Enhanced Options	00	
94	SFF-8472 Compliance	09	Includes functionality described in Rev 12.4 of SFF-8472
95	CC_EXT	xx	Check code for the Extended ID Fields (addresses 64-94)
96-106	Vendor Specific, Xentino PN	xx	SFPMS xxxx
107-118	Vendor Specific, Xentino SN	xx	Manufacturer/Year/Week/SerialNumber
119-124	Vendor Specific, MAC-address	00 0F D9 xx yy zz	00:0F:D9:xx:yy:zz
125-127	Vendor Specific		Unspecified
128-255	Reserved		

7.2 Diagnostic and Control/Status Fields, Address A2h

Address	Name	Content (Hex)	Description
0-119	Standard DDM values	00	Unspecified
96	Temperature MSB	xx	Internally measured temperature, according SFF-8472
97	Temperature LSB	xx	Internally measured temperature, according SFF-8472
96	Supply Voltage MSB	xx	Internally measured supply voltage, according SFF-8472
97	Supply Voltage LSB	xx	Internally measured supply voltage, according SFF-8472
120	SW Version MSB	zz	Value zz.yy
121	SW Version LSB	yy	Value zz.yy
122	RX SNR MSB	zz	Value in dB zz.yy
123	RX SNR LSB	yy	Value in dB zz.yy
124	TX Voltage	00 or 01	0 = 1.2V _{p2p} , 1 = 2.4V _{p2p}
125-126	Vendor Specific	00	Unspecified
127	Optional Page Select	02	SFF 8472 Controls
128-247	Reserved	00	Unspecified
248	Master Slave Mode	00	0 = Master, 1 = Slave
249	Baserate MSB	00	Range 24 - 282 (1.536..18.048 Mbps), 0x0000 = AUTO
250	Baserate LSB	00	
251	Eth Speed	00	0 = AUTO, 1 = 100F, 2 = 1000F
252	HTTP / Telnet enable / disable	03	only Bit 0 - 1 supported 0bxxxxx11 Bit 0 = Telnet, Bit 1 = HTTP 0 = disabled, 1 = enabled
253	Normal / Factory Mode	00 ¹⁾	0 = Normal operation, 1 = Factory Default

1) After rebooting this value is anytime 00

R/W Bytes (I2C configurable)

8 Programming guide

8.1 Command Structure

Main Menu		
PM	FMM	CM
Performance management	Fault and maintenance management	Configuration management
	SFPVIEW RESET SERNUM SOFTUPDATE SOFTINFO STATUS TFTP SOFTUPDATE M(AIN) H(ELP)	MASTER BASERATE ETHSD FC GATEWAY NETCONFIG NETMASK SETIP TFTPIP TFTP RETRIES TFTP TIMEOUT TFTP FILEPATH TELNET ON/OFF HTTP ON/OFF COMPAT <param>/OFF PASSWORD SOFTSELECT 1/2 FACTORY DEFAULT APPLY M(AIN)

Table 8.1 Command structure according to ITU-T Rec. M.3400 (Telecommunication Management Networks)

8.2 Xentino VS86P/VS86I Software

The **Xentino VS86P/VS86I** SFP modem stores up to two software copies in the memory (EEPROM): one active software (which is working) and one upgradeable software. Device is always start from the active software. User can switch the device between software banks by using SOFTSELECT command in CLI or by selecting a corresponding radio-button in Miscellaneous tab in WEB.

After selecting of another software bank, the unit restarts from newly selected software. This software becomes active, while another software bank becomes upgradeable.

User can download a new software version into upgradeable software bank by using 1K-XMOEM or TFTP protocols, see Chapter 9 Software download.

During upgrade, the downloaded software overwrites the upgradeable software. After successful download, a message appears that the SW was loaded successfully and user can use SOFTSELECT command to activate the downloaded software.

If downloading was interrupted or there was a failure in the data transmission, a message is displayed. The SOFTINFO command in CLI or Miscellaneous tab in WEB show that no valid software is loaded. In this case a new attempt of downloading can be performed by user.

8.3 Configuration and Application Storage

The device has three configurations: running configuration, startup configuration and a new configuration.

The **running configuration** contains all configuration values guarantee the current operation of the modem. If two modems have the same version of the software and the same running configuration they should operate equally. The running configuration is stored in the RAM of the modem. The current parameters determine the operation until the next restart or any actions on the running configuration (storage and etc.). During initialization, the initial parameters of the running configuration are loaded from the startup configuration.

The **startup configuration** contains all configuration values which will be used to configure the modem after its restart. The startup configuration is stored in EEPROM and is used to initialize the running configuration during the system start-up.

The **new configuration** stores changes in configuration parameters. The new configuration is stored in the modem RAM. After setting all necessary changes, the system administrator applies changes, and new configuration values are written from the new configuration into the running and startup configurations.

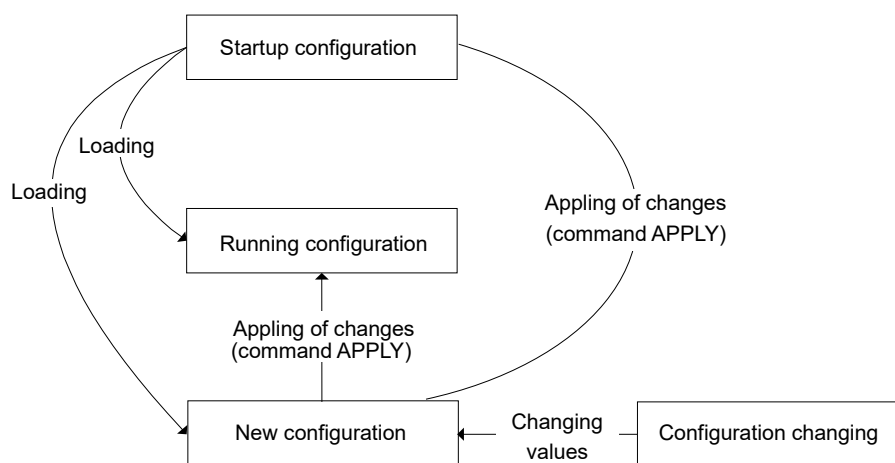

Figure 8.1 Operations of configuration parameters that should be confirmed

8.4 Command Syntax

The following rules are used to describe commands:

- parameters in angular brackets < > are obligatory
- parameters in direct brackets [] are not obligatory
- the symbol (/) between parameters requires to enter one of the listed parameters
- in real commands brackets and vertical line are not entered, they are used for description
- after the command is typed, press <enter>

8.5 Commands

Main Menu

The main menu is presented as shown below:

```
MODEL COPSFPMPSPAM
HW 01AA
SW 1.9
DATE 17-11-2025
RUNS 0d 00:15:49
ALARM NOT URGENT (SW)
MODEL_DESC Xentino SFP/100BASE-FX 1000BASE-X/Copper 1.536-18.048 Mbps
IP 192.168.0.1
```

```
----- Main Menu -----
2. Fault and maintenance management (FMM)
3. Configuration management (CM)
5. Exit
-----
Select [1..5]
CX_MM>
```

To select the desired sub-menu, type the appropriate number: “2” or “3” and press <enter>.

Type “5” and press <enter> to exit telnet session.

System Invitation

The following format of the system invitation is used in all menus:

CX_<sf>>

sf is the short form of the current menu:

- MM – Main Menu
- FMM – Fault and Maintenance Management
- CM – Configuration Management).

For example: CO_CM>

means the modem is in the Master mode and we are in the Configuration Management menu.

General Commands

<H> Command

After the <H> command is entered the modem displays the help table.

<M> Command

After this command is entered the device jumps to and displays the main menu.

Fault and Maintenance Management Menu

After typing “2” in the main menu and pressing <enter>, the following message is displayed:

```
Fault and maintenance management activated
Enter 'M' to return to MAIN, or 'H' for HELP information
```

```
CX_FMM>
```

<H> Command

Type **h** and the monitor lists all available commands in the fault and maintenance sub-menu. If you type **H [command]** you will get additional help on [command].

```
-----
Type 'H [command]' to get additional help on [command]
```

```
SFPVIEW          Collect status and modem configuration
RESET            Hardware reset of the unit
SERNUM           Show serial number
SOFTUPDATE       Update software
SOFTINFO         List loaded software
STATUS           Show system information
TFTP SOFTUPDATE  Perform maintenance over TFTP
M                Return to Main Menu
H                Show available commands
```

```
-----
CX_FMM>
```

<SFPVIEW> Command

This is a single command that collects and displays the SFP module configuration, its status in a readable format. It is helpful to get an overview of the modem with just one command:

```
CX_FMM>SFPVIEW
MODEL COPSFPMSPAM
HW      01AA
SW      1.9
DATE    17-11-2025
RUNS    0d 00:13:43
ALARM   NO
MODEL_DESC Xentino SFP/100BASE-FX 1000BASE-X/Copper 1.536-18.048 Mbps
IP      192.168.0.1
MAC     00-0F-D9-18-8E-F0
```

```
----- Main Menu -----
2. Fault and maintenance management (FMM)
3. Configuration management (CM)
```

5. Exit

Select [1..5]

1: * ver.: 1.9, date: 17-11-2025, length: 516096 bytes, CRC: 0x4f2c, fixed
2: ver.: 1.9, date: 17-11-2025, length: 516096 bytes, CRC: 0x4f2c, fixed
FPGA ver.: 31-10-2023

Status

Mode: master
Baserate: 157 10.000 Mbps
SNR: 30.50 dB good

LAN / FC: 1000F / on

Voltage: 3.260 V
Temperature: 45.17 C
Software: ok

SFP Switch: normal

Configuration

Copper settings

Mode : MASTER
Copper Baserate : 157 10.000 Mbps

System settings

IP address : 192.168.0.1 MAC address 00-0F-D9-18-8E-F0
Subnet mask : 255.255.255.0
Default gateway : 192.168.0.254
Speed : 1000F
Flow control : ON

Services

: TELNET, HTTP
TFTP server IP :
TFTP retries : 3
TFTP timeout : 10 s
TFTP file path : SFPMS_V1-7.bin
Compatibility : OFF

A0 EEPROM

000 0x00,04,00,00,00,00,00,00 // // // // //
008 0x00,40,00,00,00,00,00,00 ,@, // // // // //
016 0x00,00,c8,fa,46,6c,65,78 // // // // // ,F,l,e,x
024 0x44,53,4c,20,20,20,20,20 D,S,L, // // // // //
032 0x20,20,20,20,00,00,0f,d9 // // // // //
040 0x43,4f,50,53,46,50,4d,53 C,O,P,S,F,P,M,S
048 0x50,41,4d,20,20,20,20,20 P,A,M, // // // // //
056 0x31,2e,30,20,00,00,00,18 1,0, // // // // //
064 0x00,12,00,00,42,50,52,32 // // // // // ,B,P,R,2
072 0x34,30,38,30,30,30,30,32 4,0,8,0,0,0,0,2
080 0x20,20,20,20,32,34,30,32 // // // // // ,2,4,0,2
088 0x30,31,20,20,20,00,09,c8 0,1, // // // // //
096 0x53,46,50,4d,53,20,20,30 S,F,P,M,S, // // // // // ,0
104 0x31,41,41,42,50,52,32,34 1,A,A,B,P,R,2,4
112 0x30,38,30,30,30,30,32,00 0,8,0,0,0,0,2,
120 0x0f,d9,18,8e,f0,00,00,00 // // // // //
128 0x00,00,00,00,00,00,00,00 // // // // //
136 0x00,00,00,00,00,00,00,00 // // // // //
144 0x00,00,00,00,00,00,00,00 // // // // //
152 0x00,00,00,00,00,00,00,00 // // // // //
160 0x00,00,00,00,00,00,00,00 // // // // //
168 0x00,00,00,00,00,00,00,00 // // // // //
176 0x00,00,00,00,00,00,00,00 // // // // //
184 0x00,00,00,00,00,00,00,00 // // // // //
192 0x00,00,00,00,00,00,00,00 // // // // //
200 0x00,00,00,00,00,00,00,00 // // // // //
208 0x00,00,00,00,00,00,00,00 // // // // //
216 0x00,00,00,00,00,00,00,00 // // // // //
224 0x00,00,00,00,00,00,00,00 // // // // //
232 0x00,00,00,00,00,00,00,00 // // // // //
240 0x00,00,00,00,00,00,00,00 // // // // //
248 0x00,00,00,00,00,00,00,00 // // // // //

A2 EEPROM

000 0x00,00,00,00,00,00,00,00 // // // // //
008 0x00,00,00,00,00,00,00,00 // // // // //
016 0x00,00,00,00,00,00,00,00 // // // // //
024 0x00,00,00,00,00,00,00,00 // // // // //
032 0x00,00,00,00,00,00,00,00 // // // // //
040 0x00,00,00,00,00,00,00,00 // // // // //
048 0x00,00,00,00,00,00,00,00 // // // // //
056 0x00,00,00,00,00,00,00,00 // // // // //
064 0x00,00,00,00,00,00,00,00 // // // // //
072 0x00,00,00,00,00,00,00,00 // // // // //
080 0x00,00,00,00,00,00,00,00 // // // // //

```

088 0x00,00,00,00,00,00,00,00,00,00 , , , , , , , ,
096 0x2d,5f,7f,6c,00,00,00,00,00 ,_, ,1, , , , ,
104 0x00,00,00,00,9d,00,00,00,00,00 , , , , , , , ,
112 0x00,00,00,00,00,00,00,00,00,00 , , , , , , , ,
120 0x01,07,1e,32,01,00,00,00,02 , , , ,2, , , , ,
128 0x00,00,00,00,00,00,00,00,00,00 , , , , , , , ,
136 0x00,00,00,00,00,00,00,00,00,00 , , , , , , , ,
144 0x00,00,00,00,00,00,00,00,00,00 , , , , , , , ,
152 0x00,00,00,00,00,00,00,00,00,00 , , , , , , , ,
160 0x00,00,00,00,00,00,00,00,00,00 , , , , , , , ,
168 0x00,00,00,00,00,00,00,00,00,00 , , , , , , , ,
176 0x00,00,00,00,00,00,00,00,00,00 , , , , , , , ,
184 0x00,00,00,00,00,00,00,00,00,00 , , , , , , , ,
192 0x00,00,00,00,00,00,00,00,00,00 , , , , , , , ,
200 0x00,00,00,00,00,00,00,00,00,00 , , , , , , , ,
208 0x00,00,00,00,00,00,00,00,00,00 , , , , , , , ,
216 0x00,00,00,00,00,00,00,00,00,00 , , , , , , , ,
224 0x00,00,00,00,00,00,00,00,00,00 , , , , , , , ,
232 0x00,00,00,00,00,00,00,00,00,00 , , , , , , , ,
240 0x00,00,00,00,00,00,00,00,00,00 , , , , , , , ,
248 0x00,00,9d,02,03,00,00,00,00 , , , , , , , ,

```

CX_FMM>

<RESET> Command

This command restarts the modem.

CX_FMM>RESET

<SERNUM> Command

This command shows the production serial number of the unit.

CX_FMM>SERNUM

BPR242200002

CX_FMM>

<SOFTUPDATE> Command

This command lets you update software of the device. When prompted, send new software using 1K-XModem from your terminal application.

CX_FMM>SOFTUPDATE

Erase Memory

Start Softupdate via XModem or 1K XModem

CCC

After successful download, a message appears:

Softupdate ok.

To activate the downloaded software use the SOFTSELECT command in the CM menu

CX_FMM>

If the downloading failed or was interrupted, a message is displayed too, and the modem returns to the usual operation mode. (The operator can try again to download the software.):

CX_FMM>SOFTUPDATE

Erase Memory

Start Softupdate via XModem or 1K XModem

C

Softupdate failed

CX_FMM>

<SOFTINFO> Command

This command lists information on software and FPGA loaded into device. The list has two software entries. The Running software version is marked with an asterisk.

CX_FMM>SOFTINFO

```
1: * ver.: 1.9, date: 17-11-2025, length: 516096 bytes, CRC: 0x4f2c, fixed
2:  ver.: 1.9, date: 24-11-2025, length: 516096 bytes, CRC: 0x4f2c, fixed
FPGA ver.: 31-10-2023
```

CX_FMM>

- **ver** – The number of the software version.
- **date** – The date of the software creation.
- **length** – The size in bytes.
- **CRC** – The CRC of the image.
- **FPGA ver** - The date of the FPGA firmware loaded

If a software update is executed, the new software will be loaded to the bank with no asterisk.

If the downloading failed, the downloading was interrupted or the software is damaged then it is shown in the list:

CX_FMM>SOFTINFO

```
1: * ver.: 1.9, date: 17-11-2025, length: 516096 bytes, CRC: 0x4f2c, fixed
2:  ver.: No valid software loaded
FPGA ver.: 31-10-2023
```

CX_FMM>

<STATUS> Command

This command displays the actual status of the SFP module:

```
-----
Status
-----
Mode:          master
Baserate:     282          18.048 Mbps
SNR:          30.00 dB    good

LAN / FC:     100F / on

Voltage:      3.276 V
Temperature:  47.45 C
```

Software: bank 2 not programmed

SFP Switch: normal

CX_FMM>

Parameter	Value / Description
Mode	<ul style="list-style-type: none">• master: connection to remote side is established, SFP is in the master mode• slave: connection to remote side is established, SFP is in the slave mode• training: active SFP at the remote side is detected, handshake is in progress• cable problem: the remote SFP is inactive or cable is broken/shorted/too long
Baserate	Achieved Baserate (Achieved data transmission rate in Mbps)
SNR	<ul style="list-style-type: none">• Signal to noise ratio in dB• Link quality: poor / marginal / good
LAN	Operation mode of the host Ethernet interface: <ul style="list-style-type: none">• 100F: 100Mbit/s, full-duplex (100Base-FX)• 1000F: 1000Mbit/s, full-duplex (1000Base-X)
FC	Flow control mode of the host Ethernet interface
Voltage	The measured VCC voltage coming to SFP from the host in Volts.
Temperature	SFP temperature [C°]
Software	Software status: ok / bank x not programmed
SFP Switch	normal / factory default position

<TFTP SOFTUPDATE [FILEPATH]> Command

This command updates software from TFTP server. If no FILEPATH is entered, then the file path entered in Configuration Menu will be used.

Examples:

- TFTP SOFTUPDATE – SW update with file and path from configuration menu
- TFTP SOFTUPDATE APP.BIN – SW update with APP.BIN file located in the default tftp directory

```
CX_FMM>TFTP SOFTUPDATE
```

```
Start Softupdate via TFTP
```

```
#
```

After successful download, a message appears:

```
Received 516096 bytes
```

```
Softupdate ok.
```

```
To activate the downloaded software use the SOFTSELECT command in the CM menu
```

```
CX_FMM>
```

If the downloading failed or was interrupted, a message is displayed too, and the modem returns to the usual operation mode. (The operator can try again to download the software.):

```
Softupdate failed
```

```
CX_FMM>
```

Configuration Management Menu

After typing "3" in the main menu and pressing <enter>, the following message is displayed:

```
Configuration management activated
```

```
Enter 'M' to return to MAIN, or 'H' for HELP information
```

```
CX_CM>
```

<H> Command

Type **h** and the monitor lists all available commands in the configuration management sub-menu. If you type **H [command]** you will get additional help on [command].

```
-----  
Type 'H [command]' to get additional help on [command]
```

```
MASTER          Set Master mode  
BASERATE        Set Baserate to M*64k  
ETHSD           Set Ethernet port speed  
FC              Set Ethernet port flow control  
GATEWAY         Set IPv4 gateway address  
NETCONFIG       Show network configuration  
NETMASK         Set IPv4 netmask address  
SETIP           Set IPv4 ip address  
TFTPIP          Set IPv4 tftp address  
TFTP RETRIES    Set number of retries for TFTP server  
TFTP TIMEOUT    Set TFTP response timeout (s)  
TFTP FILEPATH   Set TFTP filename and path  
TELNET          Enable/disable TELNET service  
HTTP            Enable/disable HTTP service  
COMPAT          Set manufacturer compatibility  
PASSWORD        Set the Password  
SOFTSELECT      Select execution software 1 or 2  
FACTORY DEFAULT Setup the Factory DEFAULT  
APPLY           Apply and save changes  
M               Return to Main Menu  
H               Show available commands
```

CX_CM>

<MASTER ON/OFF> Command

This command sets Master/Slave mode of Copper Wire link.

Examples:

- MASTER ON – set Master mode
- MASTER OFF – set Slave mode

CX_CM>MASTER ON

Note: Usually, in a data transmission systems one device should be configured as a Master, while the device at the other side of the line must be configured as a Slave.

Xentino VS86P/VS86I SFP modems are able to detect during the handshake process what mode the opposite SFP modem is set to. In case both SFP modems are set to the same mode, the mode of one SFP modem might be changed automatically. Despite this, it is recommended to set one SFP modem to Master mode and the other to Slave mode, as this will reduce the connection establishment time.

The Factory Default setting is Master.

<BASERATE M/AUTO> Command

The BASERATE M command sets speed of the copper link. Parameter M defines transmission rate in the copper link in 64 kbps/s increments in the range from 24 (1.536 Mbps) to 282 (18.048 Mbps) and sets Fixed Rate Mode:

Example:

- BASERATE 282 – set speed of Copper Wire connection to 282 x 64kbps = 18.048Mbps

CX_CM>BASERATE 282

If both modems in a link operate in Fixed Rate Mode, then their BASERATEs must be equal. In this case the connection will be established fast, within 2..10 seconds. However, line parameters must allow link establishing with the specified BASERATE, otherwise the communication will not be established.

If both modems are set to Fixed Rate Mode, but with different BASERATE, then the communication will not be established.

The BASERATE command with parameter AUTO sets Auto Rate Mode:

Example:

- BASERATE AUTO – set Auto Rate Mode

CX_CM>BASERATE AUTO

If both modems in a link are set to Auto Rate Mode, the link will be established at the maximum possible speed, at which the signal/noise ratio (SNR) will be in the “good” range (see <STATUS> Command).

If Master modem is set to Fixed Rate Mode and the Slave is set to Auto Rate Mode, the connection will be established at the BASERATE of the modem in Fixed Rate Mode. However, line parameters must allow link establishing with the specified BASERATE, otherwise the communication will not be established.

If Master modem is set to Auto Rate Mode then the Slave modem must be set to Auto Rate Mode too.

The Factory Default setting is Auto Rate Mode (BASERATE AUTO).

<ETHSD 100/1000/AUTO> Command

The <ETHSD 100/1000> command sets the operating mode of the SFP Ethernet port toward host, where 100/1000 is the rate of 100 Mbit/s (i.e., 100Base-FX) or 1000 Mbit/s (1000Base-X).

The <ETHSD AUTO> command activates the rate auto detection.

```
CX_CM>ETHSD 100
```

```
CX_CM>ETHSD AUTO
```

The Factory Default setting is AUTO.

<FC ON/OFF> Command

This command enables and disables IEEE 802.3x flow control on SFP Ethernet port toward host.

```
CX_CM>FC ON
```

The Factory Default setting is ON.

<GATEWAY X.X.X.X> Command

This command sets the default IP address of the router.

```
CX_CM>GATEWAY 192.168.0.254
```

The Factory Default setting is 192.168.0.254

<NETCONFIG> Command

This command displays the running configuration:

```
-----  
Configuration  
-----  
  
Copper settings  
Mode : MASTER  
Copper Baserate : 282 18.048 Mbps  
  
System settings  
IP address : 192.168.0.182 MAC address 00-0F-D9-18-8E-FB  
Subnet mask : 255.255.255.0  
Default gateway : 192.168.0.254  
Speed : AUTO  
Flow control : ON
```

```

Services          : TELNET, HTTP

TFTP server IP   : 192.168.0.191

TFTP retries     : 3

TFTP timeout     : 10 s

TFTP file path   : SFPMS_V1-0.bin

```

CX_CM>

Copper settings	
Mode	Master / Slave mode of Copper Wire connection
Baserate	Baserate and data transmission rate in Mbps or Auto in Auto Rate mode.
System settings	
IP address	IP address of the SFP modem
MAC address	MAC address of the SFP modem
Subnet Mask	Network mask of the SFP modem
Default Gateway	Default gateway of the SFP modem
Speed	Operation mode of the Ethernet interface toward host
Flow control	Flow control mode of the Ethernet interface toward host
Priv password	Privacy password (SNMP v3)
Services	
Services	List of running management servers
TFTP server IP	IP address of the TFTP server
TFTP retries	Number of attempts to query the TFTP server
TFTP timeout	Time out for TFTP server response
TFTP file path	SW update filename and the TFTP server directory

After successful execution of a command that changes any parameter showed by NETCONFIG, the new configuration is shown. The warning message explaining that user should apply the settings and the unit will restart:

```

Enter APPLY to activate and save the new Parameter
The unit will restart
CX_CM>

```

<NETMASK X.X.X.X> Command

This command sets the subnet mask of the SFP modem.

```
CX_CM>NETMASK 255.255.255.0
```

The Factory Default setting is 255.255.255.0

<SETIP X.X.X.X> Command

The <SETIP A.B.C.D> command sets the IP-address of the SFP modem. The parameter A, B, C and D can take values from 0 to 255 (note that neither address of the network nor the address of the node can be equal to 0, or to 255).

```
CX_CM>SETIP 192.168.0.182
```

The Factory Default setting is 192.168.0.1

<TFTPIP IP/OFF> Command

This command sets TFTP address of TFTP server.

```
CX_CM>TFTPIP 192.168.0.191
```

The Factory Default setting is no TFTP address.

<TFTP RETRIES [1..10]> Command

This command configures number of attempts to query the TFTP server.

```
CX_CM>TFTP RETRIES 3
```

The Factory Default setting is 3.

<TFTP TIMEOUT [1..60]> Command

This command defines how long modem should wait for a response of TFTP server. Then modem will repeat request as many times as configured with TFTP RETRIES command.

```
CX_CM>TFTP TIMEOUT 10
```

The Factory Default setting is 10.

<TFTP FILEPATH [str]> Command

This command defines the SW update filename and the TFTP server directory. The string length [str] is limited to 80 char.

```
TFTP FILEPATH SFPMS_V1-0.BIN
```

The Factory Default setting is SFPMS_V1-0.BIN

<TELNET ON/OFF> Command

This command turns TELNET service ON and OFF.

Note: Default running management servers are TELNET and HTTP

<HTTP ON/OFF> Command

This command turns HTTP service ON and OFF.

```
CX_CM>HTTP ON
```

Note: Default running management servers are TELNET and HTTP

<COMPAT <param>/OFF> Command

This command turns Compatibility modes ON and OFF for selected Manufacturer.

```
CX_CM>COMPAT BELDENH
```

Note: The Factory Default setting is OFF.

If BELDENH is selected, also the white-list file "Xentino_shdsl_wl.bin" must be installed on the Belden switch.

<PASSWORD > Command

This command sets the Password.

```
CX_CM>PASSWORD
```

Note: The Factory Default setting is no Password. The username is anytime "admin"

<SOFTSELECT 1/2> Command

This command is used to select the active software bank from software banks 1 or 2.

```
CX_CM>SOFTSELECT 2
Selected SW ok. Will restart in 3 seconds
```

<FACTORY DEFAULT> Command

This command reset SFP modem settings to their factory default values.

```
CX_CM>FACTORY DEFAULT
Do You really want to setup the Unit to its factory defaults? (Y/N) Y
Factory default done. Will restart in 3 seconds
```

The factory default configuration is following:

```
-----
Configuration
-----
Copper settings
  Mode       : MASTER
  Copper Baserate : 1000F      --.--- Mbps
System settings
  IP address   : 192.168.0.1      MAC address 00-0F-D9-18-8E-FB
  Subnet mask  : 255.255.255.0
  Default gateway : 192.168.0.254
  Speed       : 1000F
  Flow control : ON
Services     : TELNET, HTTP
  TFTP server IP : (not set)
  TFTP retries   : 3
  TFTP timeout  : 10 s
  TFTP file path : SFPMS_V1-7.bin
Compatibility : OFF
-----
CX_CM>
```

<APPLY> Command

This command is used to apply and save configuration changes.

```
CX_CM>APPLY
```

9 Software download

The **Xentino VS86P/VS86I** SFP modem supports downloading new/old software versions to get some additional features or to protect the modems with a released only software version. The download of the software can be performed in following ways:

- via Ethernet (in CLI TELNET session) by using the 1K XMODEM protocol
- via Ethernet over TFTP (in CLI TELNET session or in WEB interface)

9.1 Using SOFTUPDATE cmd with 1K-XMODEM (fastest method)

- Run the Hyper Terminal program (hypertrm.exe) and open a TCP/IP(Winsock) Telnet session
- Open the FMM menu and enter SOFTUPDATE

```
CX_FMM>SOFTUPDATE
Erase Memory
```

Start Softupdate via XModem or 1K XModem
CC

- When the message above arises open “Send File” in the “Transfer” menu

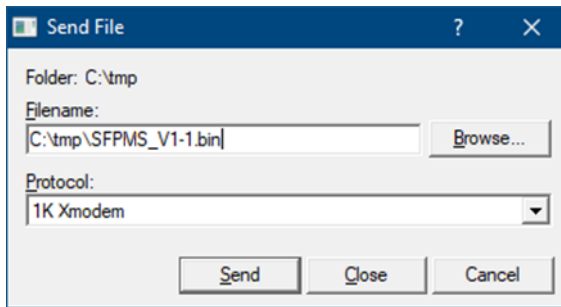

- Select 1K-Xmodem in the “Protocol” drop-down menu. Browse the SFPMS_Vx.x.bin file in the “Filename” field (the name of the file depends on the software version). Click “Send.” The Hyper Terminal starts downloading the file and saves it to the memory bank. After the Send button is clicked, the “1K-Xmodem file send for...” window pops up.

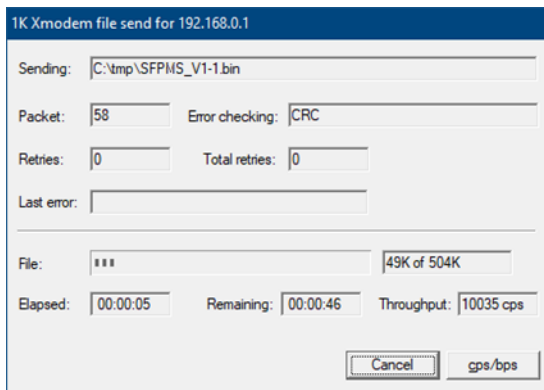

- After loading the software, the "1K Xmodem file send for..." window will close automatically and the following message must appear.

```
Softupdate ok.  
To activate the downloaded software use the SOFTSELECT command in the CM menu
```

- Change to the CM menu and enter SOFTSELECT x where x is the selected software (1 or 2)
- Wait until the unit finishes rebooting
- Open the FMM menu and enter SOFTINFO cmd, check if the desired software is activated

```
CX_FMM>SOFTINFO  
1: * ver.: 1.9, date: 17-11-2025, length: 516096 bytes, CRC: 0x4f2c, fixed  
2:  ver.: 1.9, date: 17-11-2025, length: 516096 bytes, CRC: 0x4f2c, fixed  
FPGA ver.: 31-10-2023  
  
CX_FMM>
```

9.2 Using TFTP SOFTUPDATE cmd

- Run the Hyper Terminal program (hypertm.exe) and open a TCP/IP(Winsock) Telnet session
- Open the CM menu and setup the TFTP parameters TFTP_IP and TFTP_FILEPATH

9.3 SW Update using WEB

SW Update over WEB interface can only be done by using a TFTP web server.

Configuring through WEB

- Open the CONFIGURATION page in the WEB and setup the marked parameters below according to Your requirements.
- Open the TFTP Server and make sure the software file is in the file path selected from the TFTP server (and FILEPATH)

Configuration

Network

IP address: 192.168.0.1
Subnet mask: 255.255.255.0
Gateway: 192.168.0.254
Speed: 1000F
Flow control

Copper wire

Mode: MASTER
Baserate: 157 10.000 Mbps

Services

Telnet HTTP

TFTP

Server IP: 192.168.0.14
Retries: 3
Timeout: 10
SW file path: SFPMS_V1-5.bin

Compatibility

Mode: OFF

Save

- Press the <Save> and <APPLY> button and wait until the unit finishes rebooting (approx. 15 seconds)

Software update through WEB

- Open the MISCELLANEOUS page in the WEB and press the <TFTP SW Update> button
- A Status window will popup that indicates the SW update is in progress. After the SW update
- The new installed SW will be in the not selected SW bank (marked amber)

Miscellaneous

Controls

Factory Default
Reset
TFTP SW Update

Selected Software

1: ver.: 1.9, date: 17-11-2025, length: 516096 bytes, CRC: 0x4f2c, fixed
 2: ver.: 1.9, date: 17-11-2025, length: 516096 bytes, CRC: 0x4f2c, fixed

User Management

Password:
Set Password

- To activate the new software, press the radio button in the marked area
- Press the OK button in the message box that raises up after pressing the radio button. A Status window will popup that indicates the activation of the selected SW and the unit will reboot

10 Connector Description

10.1 SFP Modem Connector

SFP Module VS86P

Type – Phoenix Contact, 1815264, PTSM 0,5/ 2-HV-2,5-THR WH R32 (male), 2 pins.

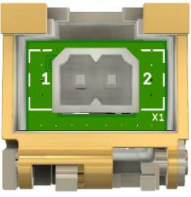
	Pin No.	Description
	1	Analog TX+/RX+
	2	Analog TX-/RX-

Matching Type for the cable:

Phoenix Contact, 1704853
 PTSM 0,5/ 2-P-2,5 WH
 For AWG 24-20
 Area 0.2–0.5 mm² or Diameter 0.5-0.8 mm

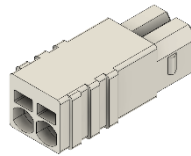

Phoenix Contact, 1015464
 PTCM 0,5/ 2-PL-2,5 WH
 For AWG 18-26
 Area 0.14–0.75 mm² or Diameter 0.4-1.0 mm

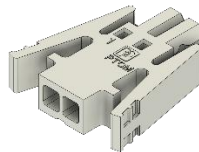

With crimp contacts:

Phoenix Contact, 1013780
 PTCM-MP-P 0,34-0,75 (for 0.34-0.75 mm²)

or

Phoenix Contact, 1013781
 PTCM-MP-P 0,14-0,5 (for 0.14-0.5 mm²)



SFP Module VS86I

Type – AMPHENOL MSPE-J2L0-E00 (female), 2 pins.

	Pin No.	Description
	1	Analog TX+/RX+
	2	Analog TX-/RX-

Matching Type for the cable:

AMPHENOL
 MSPE-P2L0-2A0
 For AWG 28-18
 Area 0.08–0.75 mm² or Diameter 0.32-1.0 mm



Matching Cables:

VS86-I0001	SPE IP20 Plug-Plug Cable 1m
VS86-I0002	SPE IP20 Plug-Plug Cable 2m
VS86-I0003	SPE IP20 Plug-Plug Cable 3m
VS86-I0004	SPE IP20 Plug-Plug Cable 4m
VS86-I0005	SPE IP20 Plug-Plug Cable 5m
VS86-I0010	SPE IP20 Plug-Plug Cable 10m
VS86-I0020	SPE IP20 Plug-Plug Cable 20m
VS86-I0050	SPE IP20 Plug-Plug Cable 50m
VS86-I0100	SPE IP20 Plug-Plug Cable 100m



10.2 SFP Host Connector

Type – realized as a PCB-Connector according to SFF-8432, chapter 4 and SFF-8419

	Pin No.	Signal	Description
20		VeeT	
19	1	VeeT	Transmit ground
18	2	TxFault	Transmit fault indication
17	3	Tx Disable	Transmit disable
16	4	SDA	SDA line (I2C)
15	5	SCL	SCL line (I2C)
14	6	MOD_ABS	Module absent
13	7	Rate Select 0	Rate select 0
12	8	LOS	Loss of signal indication
11	9	Rate Select 1	Rate select 1
	10	VeeR	Receive ground
	11	VeeR	Receive ground
	12	RD-	Receive data -
	13	RD+	Receive data +
	14	VeeR	Receive ground
	15	VccR	Receive VCC
	16	VccT	Transmit VCC
	17	VeeT	Transmit ground
	18	TD+	Transmit data +
	19	TD-	Transmit data -
	20	VeeT	Transmit ground

Top of Board

20 VeeT

19 TD-

18 TD+

17 VeeT

16 VccT

15 VccR

14 VeeR

13 RD+

12 RD-

11 VeeR

Bottom of Board (as viewed thru top of board)

1 VeeT

2 TxFault

3 Tx Disable

4 SDA

5 SCL

6 MOD.ABS

7 Rate Select 0

8 LOS

9 Rate Select 1

10 VeeR

11 Technical Specification

11.1 Interfaces

SFP Copper Wire Modem Interface

Output Voltage	2.0..2.6 Vp2p
Line Impedance	Typ. 114Ω
Transmit Bandwidth	0...13.54MHz
Number of Pairs	1
Bit Rate	1536 to 18048kbit/s
Connector Type:	

VS86P	Phoenix Contact, 1815264, 2 pin
VS86I	AMPHENOL MSPE-J2L0-E00, 2 pin
Overvoltage Protection	ITU-T Rec. K.20/K.21

SFP Host Interface

Standard:	IEEE-802.3
Data Rate	100Base-FX / 1000Base-X
Connector Type	SFP Host Connector Data (MSA Compliant)

11.2 Power Supply (SFP Host Connector Power, MSA Compliant)

Input Voltage	3.135..3.465 VDC
Input Current	Max. 255 mA
Power Consumption	Typ. 0.73 Watt
(DSL link up @18.048 Mbps, 1000Base-X host)	

11.3 SFP Latency

Latency (max.):	@1536 kbps	@10000 kbps	@18048 kbps
64-byte packets	0.788 ms	0.137 ms	0.085 ms
128-byte packets	1.144 ms	0.283 ms	0.136 ms
256-byte packets	1.670 ms	0.390 ms	0.239 ms
512-byte packets	2.980 ms	0.658 ms	0.444 ms
1024-byte packets	6.131 ms	1.250 ms	0.856 ms
1280-byte packets	7.557 ms	1.614 ms	1.061 ms
1518-byte packets	8.641 ms	1.852 ms	1.252 ms
2048-byte packets	11.530 ms	2.439 ms	1.678 ms

For a link connection (SFP to SFP) you must double this value.

11.4 SFP Jitter

Jitter (max.):	
1536 kbps	3.2 us
10000 kbps	1.0 us
18048 kbps	1.2 us

11.5 Environment

Climatic Conditions

Storage:	ETS 300 019-1-1 Class 1.2	(-40°C ... +85°C) extended temperature range
Transportation:	ETS 300 019-1-2 Class 2.3	(-40°C ... +70°C)
Operation:	ETS 300 019-1-3 Class 3.2	(-40°C ... +85°C) extended temperature range

EMC and Safety Standards

Safety	EN 62368-1:2020/A11:2020 IEC 62368-1:2020/A11:2020
EMC	EN 300 386 V2.1.1:2016 EN 55032:2015/A11:2020 class B EN 55035:2017/A11:2020 criterion A EN 61000-4-2:2009 ± 8 kV contact discharge, ± 15 kV air discharge

EN 61000-4-3:2020	10 V/m (80-1000 MHz)
EN 61000-4-4:2012	± 4 kV data line
EN 61000-4-5:2014 + A1:2017	± 2 kV data line
EN 61000-4-6:2014	10 V (150 kHz-80 MHz)

11.6 ROHS / WEEE

RoHS	RoHS2 Directive 2011/65/EU and 2015/863/EU
WEEE	WEEE Directive 2012/19/EU

11.7 MTBF

MTBF	Lifetime: 1'158'748 H, λ (10^{-9} h ⁻¹) = 863, Siemens Norm SN 29500, Temperature 40°C
------	--

11.8 Mechanical Specification

Dimension VS86P:

w/o connector:	13.7(W)x68.6(D)x13.8(H) mm
with connector 1704853:	13.7(W)x74.9(D)x13.8(H) mm
with snap-in connector 1015464	14.5(W)x76.1(D)x13.8(H) mm

Dimension VS86I:

w/o connector:	13.7(W)x71.2(D)x13.8(H) mm
with connector MSPE-P2L0-2A0XX	13.7(W)x98.4(D)x13.8(H) mm
Weight w/o connector	< 0.03kg



"focus differently"